

REVISIONS			
DATE CREATED	REV	DESCRIPTION	AUTHOR
10/1/18	00	INITIAL RELEASE	J.HUA
7/30/21	01	Upd. dimensions of wettable flank	JHTAN

NOTE: REFER TO DCP FOR OFFICIAL RELEASE DATE

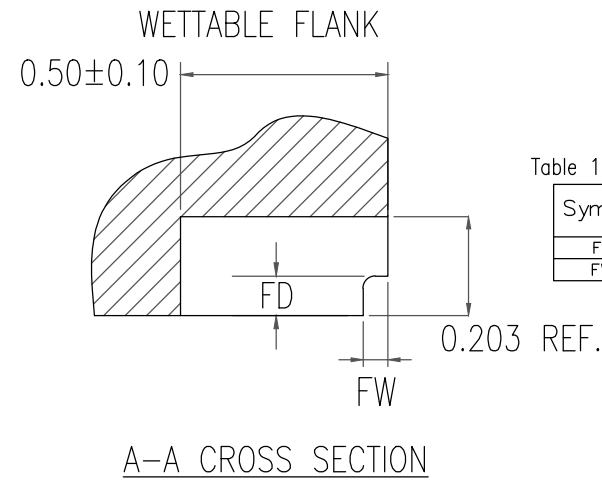
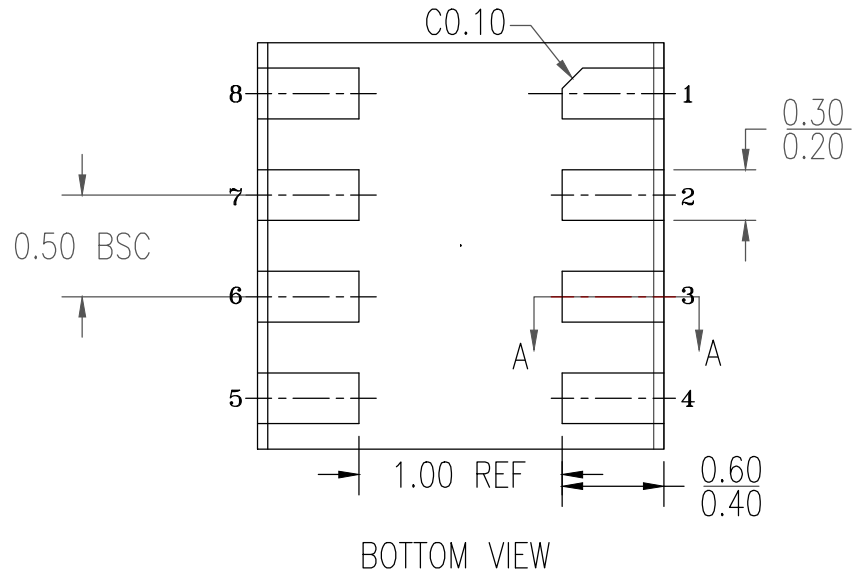
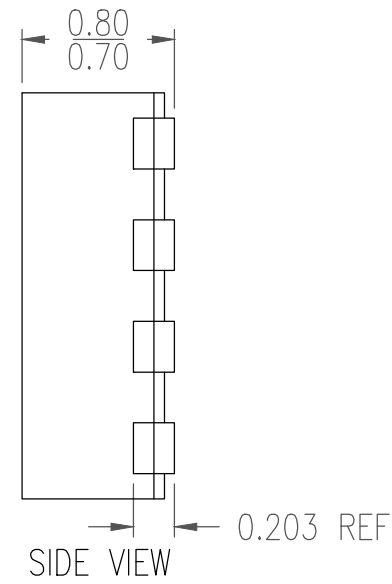
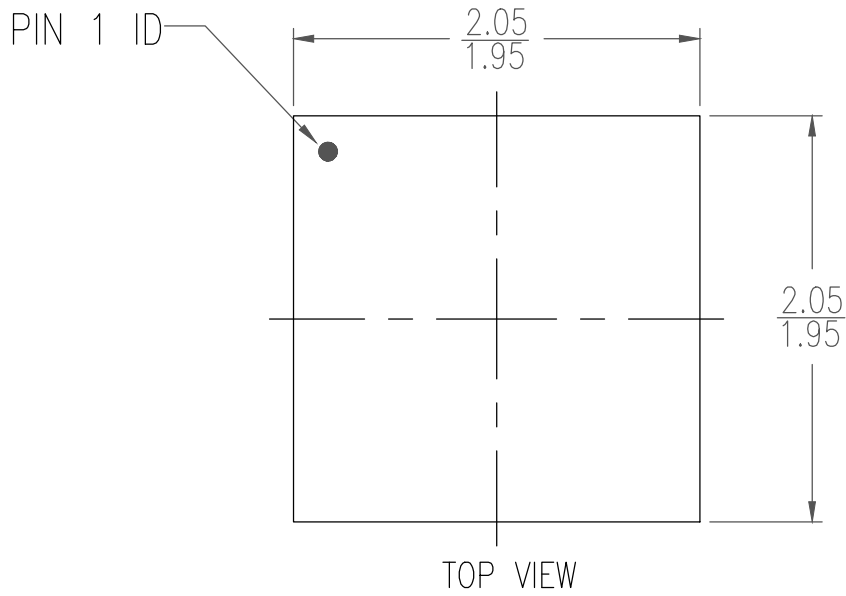

Table 1: Dimensions of wettable flank

Symbol	Unit (mm)	
	MIN	MAX
FD	0.100	-
FW	0.001	0.075

- NOTES:
1. ALL DIMENSIONING AND TOLERANCING CONFORM TO ANSI Y14.5M-1982
  2. ALL DIMENSIONS ARE IN MILLIMETERS

TOLERANCES UNLESS SPECIFIED DECIMAL ANGULAR XX± ± XXX± ± XXXX± ±	6024 SILVER CREEK VALLEY ROAD San Jose, CA 95138 PHONE: (408) 284-8200 FAX: (408) 492-8674	
	TITLE CMT8 Package Outline Drawing 2.0 x 2.0 x 0.75 mm Body 0.5mm Pitch DFN	
SIZE <b>C</b>	DRAWING No. PSC-4778	REV 01
DO NOT SCALE DRAWING		SHEET 1 OF 2

REVISIONS			
DATE CREATED	REV	DESCRIPTION	AUTHOR
10/1/18	00	INITIAL RELEASE	J.HUA
7/30/21	01	Upd. dimensions of wettable flank	JHTAN
NOTE: REFER TO DCP FOR OFFICIAL RELEASE DATE			

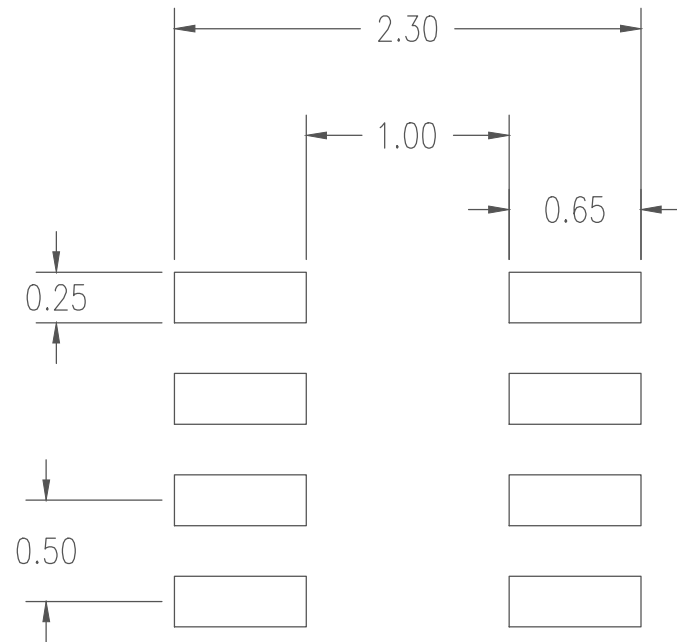

### RECOMMENDED LAND PATTERN DIMENSION

#### NOTES:

1. ALL DIMENSION ARE IN MM. ANGLES IN DEGREES.
2. TOP DOWN VIEW. AS VIEWED.
3. LAND PATTERN RECOMMENDATION PER IPC-7351B GENERIC REQUIREMENT FOR MOUNT DESIGN AND LAND PATTERN.

TOLERANCES UNLESS SPECIFIED		6024 SILVER CREEK VALLEY ROAD San Jose, CA 95138 PHONE: (408) 284-8200 FAX: (408) 492-8674		
DECIMAL	ANGULAR			
XX±	±			
XXX±				
XXXX±				
		TITLE CMT8 Package Outline Drawing 2.0 x 2.0 x 0.75 mm Body 0.5mm Pitch DFN		
		SIZE	DRAWING No.	REV
		C	PSC-4778	01
DO NOT SCALE DRAWING			SHEET 2 OF 2	