

# EU070 Smoke Detector

## Quick Start Guide

---

### Contents

1. Introduction.....	2
1.1 Scope of this document.....	2
1.2 Available documentation for EU070 Smoke Detector PoC.....	2
2. PoC Key Components Arrangement.....	3
3. PoC Board Setup.....	4
3.1 Two separable parts of the PCB.....	4
3.2 LEDs and Buttons.....	4
3.3 RL78/G12 Programming Adapter.....	4
4. Taking PoC board into service.....	5
4.1 Before Power-Up.....	5
4.1.1 Switch Position 1.....	5
4.1.2 Switch Position 2.....	5
4.2 Connecting Power Source.....	6
4.3 Power Supply OR-ing.....	6
5. User Instructions.....	7
5.1.1 Smoke Detection mode.....	7
5.1.2 Horn Test mode.....	7
6. Nomenclature.....	8
References.....	9
Revision History.....	10

## 1. Introduction

### 1.1 Scope of this document

This Quick Start Guide - Document describes the initial setup and steps required for bringing the EU070 Smoke Detector PoC into service.

The EU070 Smoke Detector PoC board demonstrated the functional principle of a photoelectronic smoke detector, based on an infrared photo diode (sender) and a photo transistor (receiver), mounted into a darkness chamber (also called smoke chamber). These two elements are positioned at an angle of 120 degree, where the light beam does not hit the photo transistor directly. The surrounding smoke can enter the smoke chamber. As a result, the light produced by the IR is scattered and detected by the photo transistor which enables an audible piezo horn alarm.

### 1.2 Available documentation for EU070 Smoke Detector PoC

Following documents touching on EU070 Smoke Detector PoC board are available as \*.pdf File:

Renesas Electronics, "EU070 – Software User Guide".

Renesas Electronics, "EU070 – Quick Start Guide".

Renesas Electronics, "EU070 – Hardware User Guide".

Additionally, please contact your Renesas Sales contact to gather more information on EU070 Smoke Detector PoC board (presentation, availability, ...)

## 2. PoC Key Components Arrangement

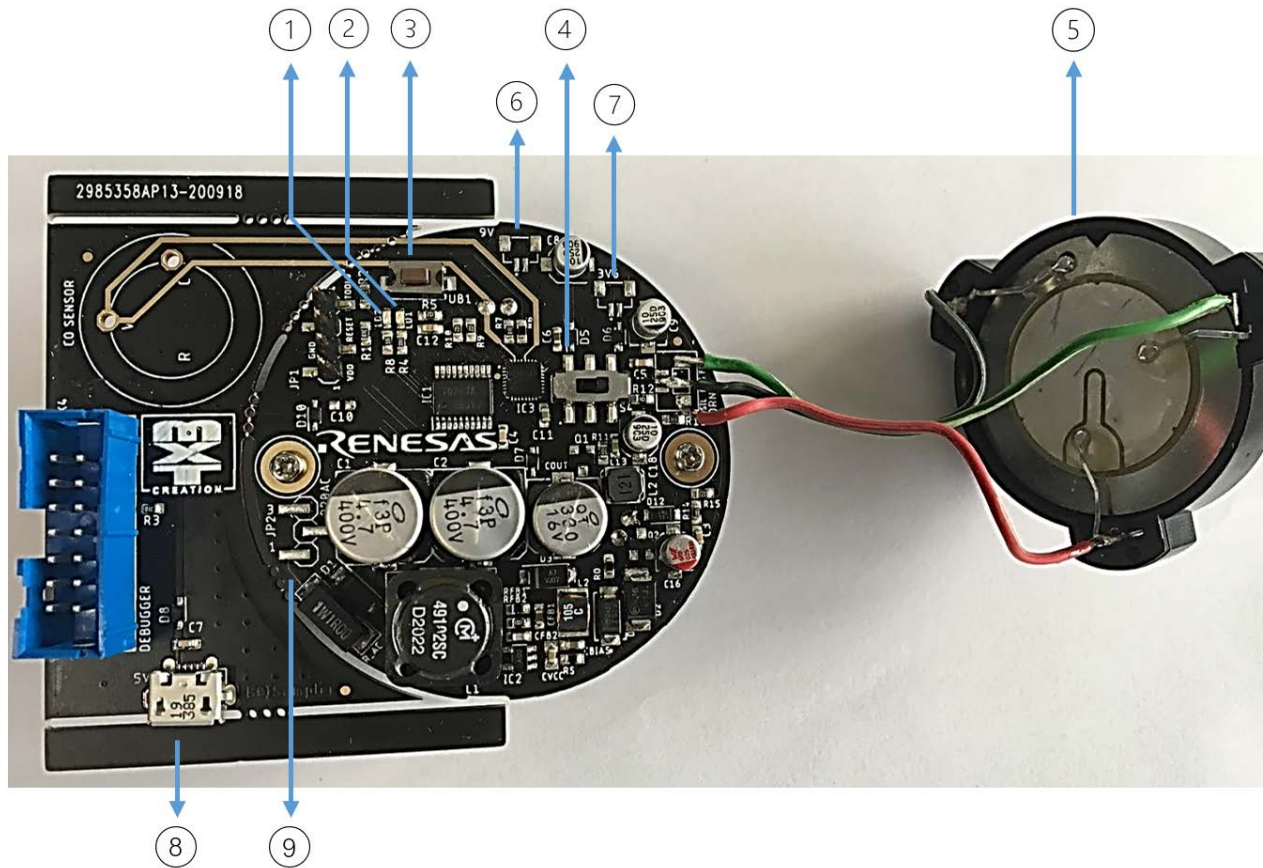

- 1) Presence LED (green)
- 2) Alarm LED (red)
- 3) Test Button
- 4) Power Supply Selection Switch
- 5) Piezo Horn
- 6) 9V DC Connector pads
- 7) 3.6V DC Connector pads
- 8) 5V DC USB Connector
- 9) AC Connector pads

For more details on EU070 Smoke Detector PoC Hardware please refer to [3] for more information.

### 3. PoC Board Setup

#### 3.1 Two separable parts of the PCB

Initial idea was: having two separable parts – left side for programming/debugging, right side as the “main” Eu070 PoC Board.

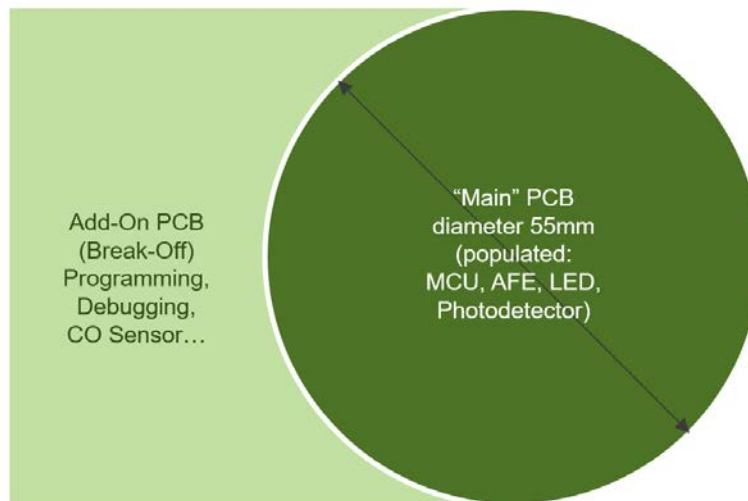

#### 3.2 LEDs and Buttons

Description of User LEDs and Buttons

- IO\_LED1 – Red alarm LED, that is enabled together with piezo horn.
- IO\_LED2 – Green presence LED, that blinks every 1 second.
- Test button – it is used for 2 possible states:
  1. **Test Horn** - turns ON the audible piezo horn and “Alarm LED” (IO\_LED1) for 3 seconds.
  2. **Smoke Detected** – After the smoke was detected, the audible piezo horn and “Alarm LED” (IO\_LED1) turns ON and can be turned OFF using the “Test button”.

#### 3.3 RL78/G12 Programming Adapter

EU070 PoC Board can either be programmed/debugged via standard Renesas E1/E2 emulator 14-pin connector (as long as the “break-off” board is still connected with the EU070 PoC Main-Board).

Please find below the schematic of the programming/debugger adapter which is required to connect the EU070 board to a standard Renesas E1/E2 emulator, when using only 4-pin connector for programming/debugging.

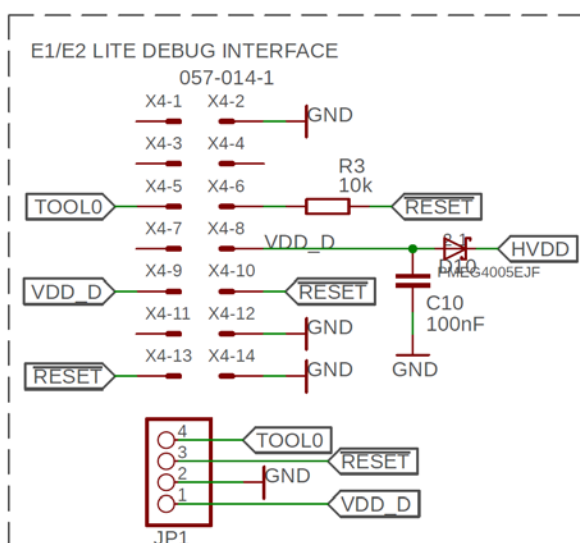

Refer to [5] for more information.

## 4. Taking PoC board into service

### 4.1 Before Power-Up

**IMPORTANT:**

The power supply selection switch must be selected manually by the user BEFORE connecting the board to the power supply source as described below:

#### 4.1.1 Switch Position 1

for power supply from 3V/5V battery and 5V micro USB connector and E1/E2 debugger.

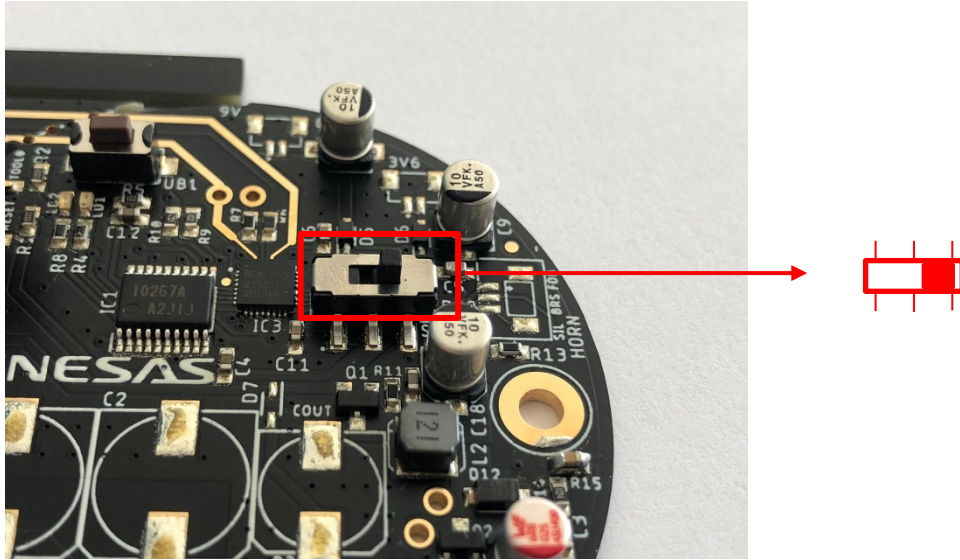

#### 4.1.2 Switch Position 2

for power supply from 9V battery and 220V AC connector.

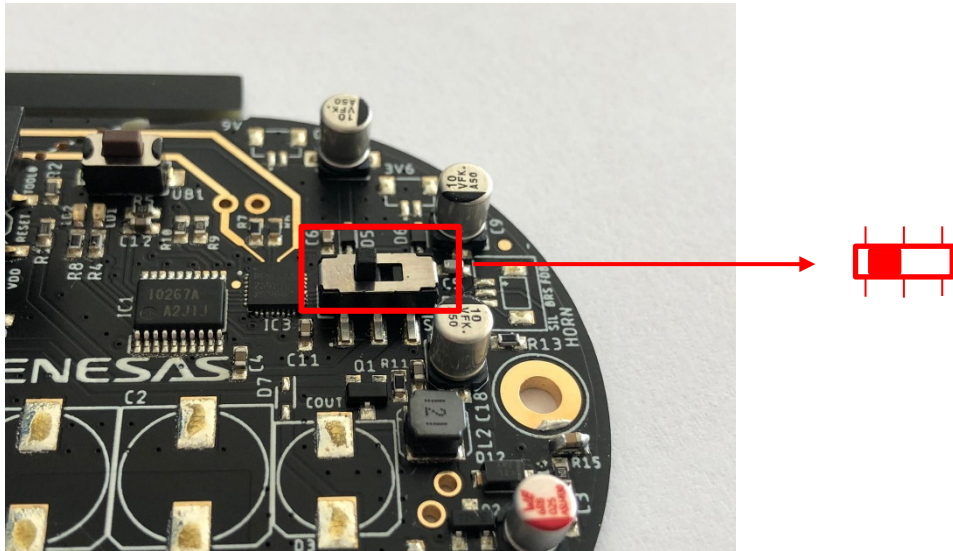

## 4.2 Connecting Power Source

Connect the desired Power Source to the EU070 PoC Board. This board offers a wide range of power supply options like:

- 3V DC Battery connector
- 5V DC microUSB connector
- 9V DC Battery connector
- 3.3V or 5VDC Debugger power supply
- **220V AC connector \*)**

### \*) 220VAC SUPPLY – ATTENTION !

The EU070 Smoke Detector PoC board offers the possibility to be supplied from 220VAC source **BUT WE CANNOT GUARANTEE** the safety of the overall circuitry & PoC Board as there is no Isolation. The user is totally responsible for the AC supply and for switch slider position.

## 4.3 Power Supply OR-ing

EU070 PoC Board is designed to support lots of different use cases, meaning also lots of different power supply options. Some of them are targeted for easy bringing-into-service (e.g. power supply via Debugger or USB connector on the „Break-Off-Board“), and some of them for real-life use cases (3 ... 5V Battery, 9V Battery, AC mains supply).

Please be aware that all of the power sources are OR-ed via Schottky Diodes and remove them accordingly if necessary for your system application setup.

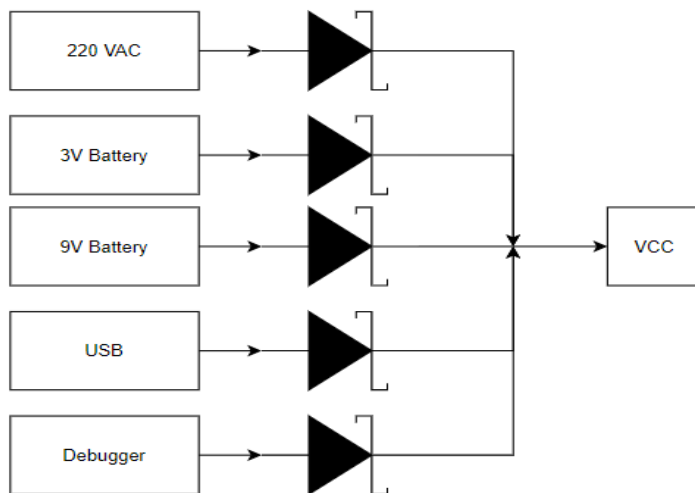

## 5. User Instructions

### 5.1.1 Smoke Detection mode

After the circuit is powered, the “Presence LED” will blink every second. When the smoke is detected, the piezo horn and the “Alarm LED” will turn ON, until the user will press the “Test horn” button. To activate the smoke detection trigger (enable piezo horn and “Alarm LED”), the user shall introduce the substantial amounts of smoke particles (smoke or dust) in the smoke chamber. The triggered alarm can be stopped by pressing the “Test horn” button.

### 5.1.2 Horn Test mode

The “Test horn” button enables the piezo horn and the “Alarm LED” of the smoke detector only if the smoke is not detected. The test horn will turn off automatically after 3 seconds.

For more details on EU070 Smoke Detector PoC Software please refer to [1] for more information.

## 6. Nomenclature

- IC Integrated Circuit
- PoC Proof of Concept
- SW Software
- HW Hardware
- MCU Microcontroller
- AFE Analog Front-End
- LED Light Emitting Diode
- IR Infrared
- TIA Transimpedance Input Amplifier
- PGA Programmable Gain Amplifier
- DAC D/A converter or Digital to Analog Converter
- ADC A/D converter or Analog to Digital Converter
- SPI Serial Peripheral Interface
- DC Direct Current
- AC Alternating Current
- LDO Low-Dropout Voltage Regulator
- GPIO General-Purpose Input/Output
- SINI System Initialization
- APP Application
- IDE Integrated development environment
- CO Carbon Monoxide



**References**

- [1] Renesas Electronics, "EU070 – Software User Guide".
- [2] Renesas Electronics, "EU070 – Quick Start Guide". [ >> *THIS DOCUMENT* << ]
- [3] Renesas Electronics, "EU070 – Hardware User Guide".
- [4] Renesas Electronics, "RL78/G12 - User's Manual: Hardware".
- [5] Renesas Electronics, "E1/E20/E2 Emulator, E2 Emulator Lite - Additional Document for User's Manual - (Notes on Connection for RL78)"

**Revision History**

Rev.	Date	Description / Summary
0.1	12.01.2021	Initial REE version

# General Precautions in the Handling of Microprocessing Unit and Microcontroller Unit Products

The following usage notes are applicable to all Microprocessing unit and Microcontroller unit products from Renesas. For detailed usage notes on the products covered by this document, refer to the relevant sections of the document as well as any technical updates that have been issued for the products.

## 1. Precaution against Electrostatic Discharge (ESD)

A strong electrical field, when exposed to a CMOS device, can cause destruction of the gate oxide and ultimately degrade the device operation. Steps must be taken to stop the generation of static electricity as much as possible, and quickly dissipate it when it occurs. Environmental control must be adequate. When it is dry, a humidifier should be used. This is recommended to avoid using insulators that can easily build up static electricity.

Semiconductor devices must be stored and transported in an anti-static container, static shielding bag or conductive material. All test and measurement tools including work benches and floors must be grounded. The operator must also be grounded using a wrist strap. Semiconductor devices must not be touched with bare hands. Similar precautions must be taken for printed circuit boards with mounted semiconductor devices.

## 2. Processing at power-on

The state of the product is undefined at the time when power is supplied. The states of internal circuits in the LSI are indeterminate and the states of register settings and pins are undefined at the time when power is supplied. In a finished product where the reset signal is applied to the external reset pin, the states of pins are not guaranteed from the time when power is supplied until the reset process is completed. In a similar way, the states of pins in a product that is reset by an on-chip power-on reset function are not guaranteed from the time when power is supplied until the power reaches the level at which resetting is specified.

## 3. Input of signal during power-off state

Do not input signals or an I/O pull-up power supply while the device is powered off. The current injection that results from input of such a signal or I/O pull-up power supply may cause malfunction and the abnormal current that passes in the device at this time may cause degradation of internal elements. Follow the guideline for input signal during power-off state as described in your product documentation.

## 4. Handling of unused pins

Handle unused pins in accordance with the directions given under handling of unused pins in the manual. The input pins of CMOS products are generally in the high-impedance state. In operation with an unused pin in the open-circuit state, extra electromagnetic noise is induced in the vicinity of the LSI, an associated shoot-through current flows internally, and malfunctions occur due to the false recognition of the pin state as an input signal become possible.

## 5. Clock signals

After applying a reset, only release the reset line after the operating clock signal becomes stable. When switching the clock signal during program execution, wait until the target clock signal is stabilized. When the clock signal is generated with an external resonator or from an external oscillator during a reset, ensure that the reset line is only released after full stabilization of the clock signal. Additionally, when switching to a clock signal produced with an external resonator or by an external oscillator while program execution is in progress, wait until the target clock signal is stable.

## 6. Voltage application waveform at input pin

Waveform distortion due to input noise or a reflected wave may cause malfunction. If the input of the CMOS device stays in the area between  $V_{IL}$  (Max.) and  $V_{IH}$  (Min.) due to noise, for example, the device may malfunction. Take care to prevent chattering noise from entering the device when the input level is fixed, and also in the transition period when the input level passes through the area between  $V_{IL}$  (Max.) and  $V_{IH}$  (Min.).

## 7. Prohibition of access to reserved addresses

Access to reserved addresses is prohibited. The reserved addresses are provided for possible future expansion of functions. Do not access these addresses as the correct operation of the LSI is not guaranteed.

## 8. Differences between products

Before changing from one product to another, for example to a product with a different part number, confirm that the change will not lead to problems. The characteristics of a microprocessing unit or microcontroller unit products in the same group but having a different part number might differ in terms of internal memory capacity, layout pattern, and other factors, which can affect the ranges of electrical characteristics, such as characteristic values, operating margins, immunity to noise, and amount of radiated noise. When changing to a product with a different part number, implement a system-evaluation test for the given product.

## Notice

1. Descriptions of circuits, software and other related information in this document are provided only to illustrate the operation of semiconductor products and application examples. You are fully responsible for the incorporation or any other use of the circuits, software, and information in the design of your product or system. Renesas Electronics disclaims any and all liability for any losses and damages incurred by you or third parties arising from the use of these circuits, software, or information.
  2. Renesas Electronics hereby expressly disclaims any warranties against and liability for infringement or any other claims involving patents, copyrights, or other intellectual property rights of third parties, by or arising from the use of Renesas Electronics products or technical information described in this document, including but not limited to, the product data, drawings, charts, programs, algorithms, and application examples.
  3. No license, express, implied or otherwise, is granted hereby under any patents, copyrights or other intellectual property rights of Renesas Electronics or others.
  4. You shall not alter, modify, copy, or reverse engineer any Renesas Electronics product, whether in whole or in part. Renesas Electronics disclaims any and all liability for any losses or damages incurred by you or third parties arising from such alteration, modification, copying or reverse engineering.
  5. Renesas Electronics products are classified according to the following two quality grades: "Standard" and "High Quality". The intended applications for each Renesas Electronics product depends on the product's quality grade, as indicated below.
    - "Standard": Computers; office equipment; communications equipment; test and measurement equipment; audio and visual equipment; home electronic appliances; machine tools; personal electronic equipment; industrial robots; etc.
    - "High Quality": Transportation equipment (automobiles, trains, ships, etc.); traffic control (traffic lights); large-scale communication equipment; key financial terminal systems; safety control equipment; etc.
- Unless expressly designated as a high reliability product or a product for harsh environments in a Renesas Electronics data sheet or other Renesas Electronics document, Renesas Electronics products are not intended or authorized for use in products or systems that may pose a direct threat to human life or bodily injury (artificial life support devices or systems; surgical implantations; etc.), or may cause serious property damage (space system; undersea repeaters; nuclear power control systems; aircraft control systems; key plant systems; military equipment; etc.). Renesas Electronics disclaims any and all liability for any damages or losses incurred by you or any third parties arising from the use of any Renesas Electronics product that is inconsistent with any Renesas Electronics data sheet, user's manual or other Renesas Electronics document.
6. When using Renesas Electronics products, refer to the latest product information (data sheets, user's manuals, application notes, "General Notes for Handling and Using Semiconductor Devices" in the reliability handbook, etc.), and ensure that usage conditions are within the ranges specified by Renesas Electronics with respect to maximum ratings, operating power supply voltage range, heat dissipation characteristics, installation, etc. Renesas Electronics disclaims any and all liability for any malfunctions, failure or accident arising out of the use of Renesas Electronics products outside of such specified ranges.
  7. Although Renesas Electronics endeavors to improve the quality and reliability of Renesas Electronics products, semiconductor products have specific characteristics, such as the occurrence of failure at a certain rate and malfunctions under certain use conditions. Unless designated as a high reliability product or a product for harsh environments in a Renesas Electronics data sheet or other Renesas Electronics document, Renesas Electronics products are not subject to radiation resistance design. You are responsible for implementing safety measures to guard against the possibility of bodily injury, injury or damage caused by fire, and/or danger to the public in the event of a failure or malfunction of Renesas Electronics products, such as safety design for hardware and software, including but not limited to redundancy, fire control and malfunction prevention, appropriate treatment for aging degradation or any other appropriate measures. Because the evaluation of microcomputer software alone is very difficult and impractical, you are responsible for evaluating the safety of the final products or systems manufactured by you.
  8. Please contact a Renesas Electronics sales office for details as to environmental matters such as the environmental compatibility of each Renesas Electronics product. You are responsible for carefully and sufficiently investigating applicable laws and regulations that regulate the inclusion or use of controlled substances, including without limitation, the EU RoHS Directive, and using Renesas Electronics products in compliance with all these applicable laws and regulations. Renesas Electronics disclaims any and all liability for damages or losses occurring as a result of your noncompliance with applicable laws and regulations.
  9. Renesas Electronics products and technologies shall not be used for or incorporated into any products or systems whose manufacture, use, or sale is prohibited under any applicable domestic or foreign laws or regulations. You shall comply with any applicable export control laws and regulations promulgated and administered by the governments of any countries asserting jurisdiction over the parties or transactions.
  10. It is the responsibility of the buyer or distributor of Renesas Electronics products, or any other party who distributes, disposes of, or otherwise sells or transfers the product to a third party, to notify such third party in advance of the contents and conditions set forth in this document.
  11. This document shall not be reprinted, reproduced or duplicated in any form, in whole or in part, without prior written consent of Renesas Electronics.
  12. Please contact a Renesas Electronics sales office if you have any questions regarding the information contained in this document or Renesas Electronics products.

(Note1) "Renesas Electronics" as used in this document means Renesas Electronics Corporation and also includes its directly or indirectly controlled subsidiaries.

(Note2) "Renesas Electronics product(s)" means any product developed or manufactured by or for Renesas Electronics.

(Rev.4.0-1 November 2017)

## Corporate Headquarters

TOYOSU                      FORESIA,                      3-2-24                      Toyosu,  
Koto-ku, Tokyo 135-0061, Japan  
[www.renesas.com](http://www.renesas.com)

## Contact information

For further information on a product, technology, the most up-to-date version of a document, or your nearest sales office, please visit:  
[www.renesas.com/contact/](http://www.renesas.com/contact/)

## Trademarks

Renesas and the Renesas logo are trademarks of Renesas Electronics Corporation. All trademarks and registered trademarks are the property of their respective owners.