

FPB-R9A02G021 Fast Prototyping Board

1. Introduction

The FPB-R9A02G021 Fast Prototyping Board provides an entry point for evaluation, prototyping and development with the R9A02G021 MCU. Moreover, since this board incorporates an emulator circuit, you can use it for designing your own applications without further investments in tools. This product includes through-holes for pin headers that allow access to all MCU signal pins, allowing easy prototyping with a breadboard.

Getting started is Easy!

1. Power up the FPB-R9A02G021 board through the Debug USB port (J17: Type-C) using an USB cable connected to a 5V power source like a PC USB port.
2. The green power LED3 will light up.
3. The pre-programmed 'blinky example project' will begin to execute blinking the green user LEDs LED1 and LED2.

2. Package Contents

- FPB-R9A02G021 v1 Board (RTK9FPG021S00001BJ)
- Printed Quick Start Guide
- Printed information for China RoHS

3. Board Specifications

Item	Specification
Evaluation MCU	Part No: R9A02G0214CNE; package: 48-pin HWQFN
	On-chip memory: 128-KB ROM, 16-KB RAM, 4-KB data flash memory
Board size	Size: 55 mm x 95 mm
Power-supply voltage	VCC: 3.3 V. MCU operation voltage range 1.6 V to 5.5 V.
Power-supply circuit	USB connector: VBUS (5 V input); VBUS is converted to 3.3 V by linear regulator.
	2-pin external power-supply header*1
Push switch	Reset switch x 1; user switch x 1
LED	Power indicator: green x 1, user: green x 2, Debug LED: yellow x 1
USB connector	Connector: USB Type-C
Pmod™ connector	Connector: Angle type, 12 pins x 2
Arduino® connector	Connector: 6 pins x 1, 8 pins x 2, 10 pins x 1 The interface is compatible with Arduino® UNO R3.
Grove® connector *1	Connector: Angle type, 4 pins x 1
MCU header*1	Header: 24 pins x 2

*1 This part is not mounted

4. Board Layout

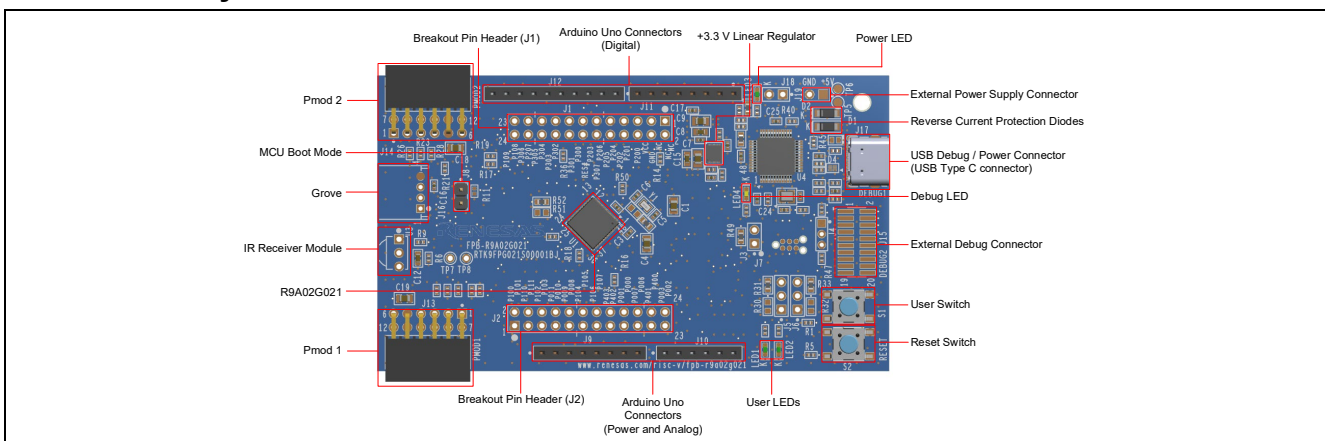

Figure 1. FPB-R9A02G021 Board Layout

5. Arduino Interface

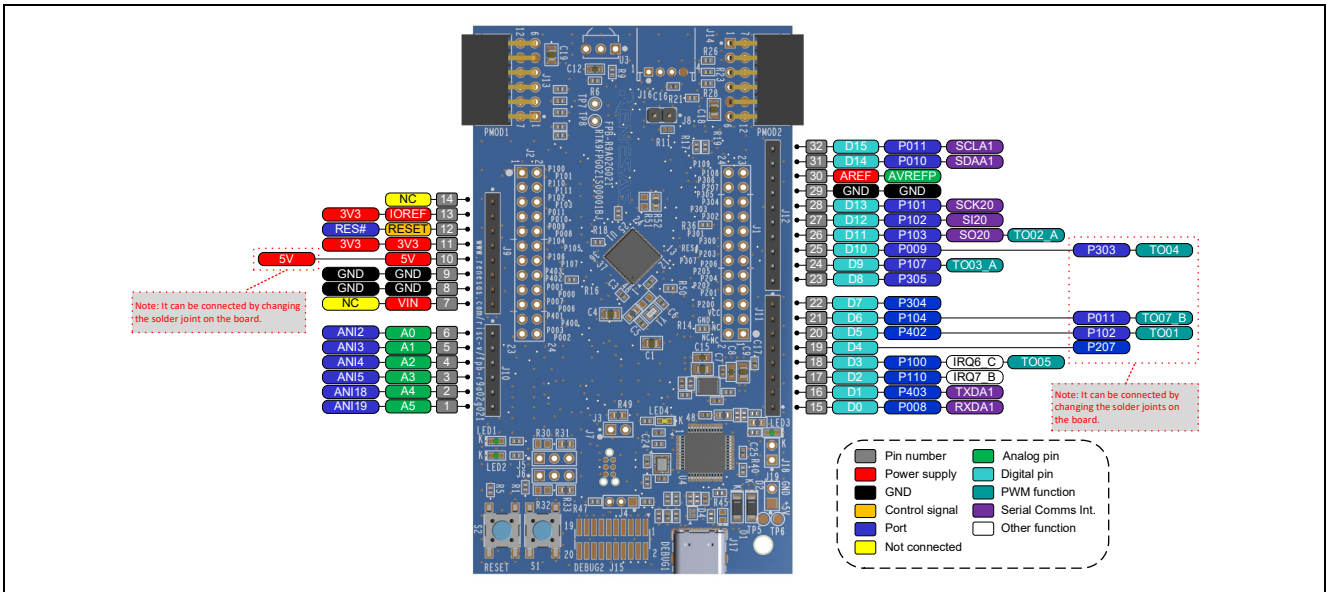

Figure 2. FPB-R9A02G021 Arduino Interface

6. Pmod Interface

The FPB-R9A02G021 Fast Prototyping Board has Pmod 1 connector for Type-2A, Type-3A and Type-6A interface and Pmod 2 for Type-3A and Type-6A interface.

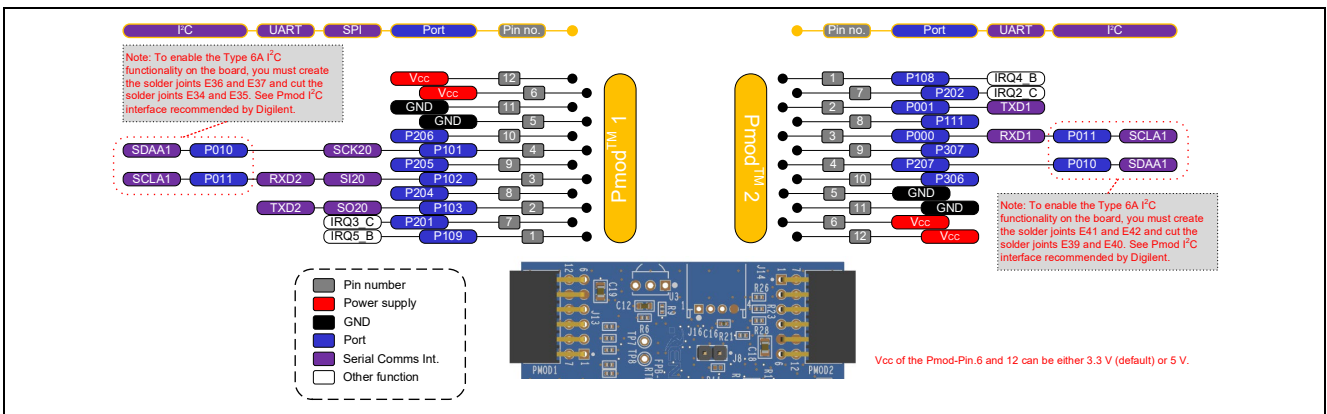

Figure 3. FPB-R9A02G021 Pmod Interface

7. Grove Interface

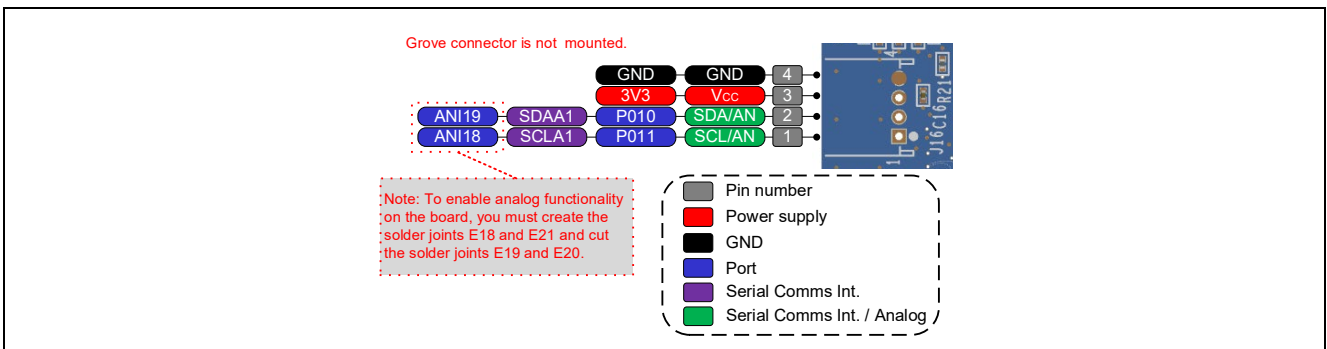

Figure 4. FPB-R9A02G021 Seed Grove Interface

8. WEB and Support

1. For detailed information on the FPB-R9A02G021 board, please refer to the FPB-R9A02G021 User's Manual available at renesas.com/risc-v/fpb-r9a02g021.
2. Renesas provides sample projects for various features of the R9A02G021 MCU. These sample projects can be used as a reference when starting application development. For application development, the integrated development environment e² studio, the compiler package LLVM for RISC-V and Renesas Flash Programmer must be installed on the host PC. These are available for download at renesas.com/risc-v/fpb-r9a02g021.

