

## FEATURES

### HIGHLIGHTS

- Single PLL chip:
  - Features 0.5 mHz to 560 Hz bandwidth
  - Provides node clock for ITU-T G.8261/G.8262 Synchronous Ethernet (SyncE)
  - Exceeds GR-253-CORE (OC-192) and ITU-T G.813 (STM-64) jitter generation requirements
  - Provides node clocks for Cellular and WLL base-station (GSM and 3G networks)
  - Provides clocks for DSL access concentrators (DSLAM), especially for Japan TCM-ISDN network timing based ADSL equipments
  - Provides clocks for 1 Gigabit and 10 Gigabit Ethernet application
  - It supports clock generation for IEEE-1588 applications

### MAIN FEATURES

- Provides an integrated single-chip solution for Synchronous Equipment Timing Source, including Stratum 3, 4E, 4, SMC, EEC-Option 1 and EEC-Option 2 Clocks
- Provides SONET clocks with less than 1.5 ps of RMS Phase Jitter (12 KHz - 20 MHz)
- Supports 1 pps input and output
- Employs PLL architecture to feature excellent jitter performance and minimize the number of the external components
- Supports programmable DPLL bandwidth from 0.5 mHz to 560 Hz
- Supports  $1.1 \times 10^{-5}$  ppm absolute holdover accuracy and  $4.4 \times 10^{-8}$  ppm instantaneous holdover accuracy
- Supports hitless reference switching to minimize phase transients on the DPLL output to be no more than 0.61 ns
- Supports programmable input-to-output phase offset adjustment
- Limits the phase and frequency offset of the outputs
- Provides OUT1~OUT6 output clocks whose frequencies cover from 1 Hz (1PPS) to 644.53125 MHz
  - 1PPS, 400 Hz, 2 kHz, 8 kHz, 64 kHz, N x E1, N x T1, N x 13.0 MHz, N x 3.84 MHz, 5 MHz, 10 MHz, 20 MHz, E3, T3, 6.48 MHz, 19.44 MHz, 25.92 MHz, 38.88 MHz, 51.84 MHz, 77.76 MHz, 25MHz, 25.78125 MHz, 125 MHz, 128.90625 MHz, 155.52 MHz or 156.25 MHz or 161.1328125 MHz for CMOS outputs
  - 1PPS, 400 Hz, 2 kHz, 8 kHz, 64 kHz, N x E1, N x T1, N x 13.0 MHz, N x 3.84 MHz, 5 MHz, 10 MHz, 20 MHz, 25 MHz, E3, T3, 6.48 MHz, 19.44 MHz, 25.92 MHz, 38.88 MHz, 51.84 MHz, 77.76 MHz, 125 MHz, 128.90625 MHz, 155.52 MHz, 156.25 MHz, 161.1328125 MHz, 311.04 MHz, 312.5 MHz, 322.265625 MHz, 622.08 MHz, 625 MHz or 644.53125 MHz for differential Outputs

- Provides IN1~IN6 input clocks whose frequencies cover from 1 Hz (1PPS) to 625 MHz
  - 1PPS, 2 kHz, 4 kHz, N x 8 kHz, 1.544 MHz, 2.048 MHz, 6.25 MHz, 6.48MHz, 10 MHz, 19.44 MHz, 25 MHz, 25.92 MHz, 38.88 MHz, 51.84 MHz, 77.76 MHz, 125MHz, 155.52 MHz or 156.25 MHz for CMOS inputs
  - 1PPS, 2 kHz, 4 kHz, N x 8 kHz, 1.544 MHz, 2.048 MHz, 6.25 MHz, 6.48 MHz, 10 MHz, 19.44 MHz, 25 MHz, 25.92 MHz, 38.88 MHz, 51.84 MHz, 77.76 MHz, 125MHz, 155.52 MHz, 156.25 MHz, 311.04 MHz, 312.5 MHz, 622.08 MHz or 625 MHz for differential inputs
- Internal DCO can be controlled by an external processor to be used for IEEE-1588 clock generation
- Supports Forced or Automatic operating mode switch controlled by an internal state machine. It supports Free- Run, Locked and Hold-over modes
- Supports manual and automatic selected input clock switch
- Supports automatic hitless selected input clock switch on clock failure
- Provides a 2 kHz, 4 kHz, 8 kHz, or 1PPS frame sync input signal, and a 2 kHz, 8 kHz, or 1PPS frame sync output signals
- Provides output clocks for BITS, GPS, 3G, GSM, etc.
- Supports PECL/LVDS and CMOS input/output technologies
- Supports master clock calibration
- Supports Master/Slave application (two chips used together) to enable system protection against single chip failure
- Supports Telcordia GR-1244-CORE, Telcordia GR-253-CORE, ITU-T G.812, ITU-T G.8262, ITU-T G.813 and ITU-T G.783 Recommendations

### OTHER FEATURES

- I2C and Serial microprocessor interface modes
- IEEE 1149.1 JTAG Boundary Scan
- Single 3.3 V operation with 5 V tolerant CMOS I/Os
- 72-pin QFN package, Green package options available

### APPLICATIONS

- 1 Gigabit Ethernet and 10 Gigabit Ethernet
- BITS / SSU
- SMC / SEC (SONET / SDH)
- DWDM cross-connect and transmission equipments
- Synchronous Ethernet equipments
- Central Office Timing Source and Distribution
- Core and access IP switches / routers
- Gigabit and Terabit IP switches / routers
- IP and ATM core switches and access equipments
- Cellular and WLL base-station node clocks
- Broadband and multi-service access equipments

## DESCRIPTION

The IDT82V3398 is an integrated, single-chip solution for the Synchronous Equipment Timing Source for Stratum 3, 4E, 4, SMC, EEC-Option1, EEC-Option2 clocks in SONET / SDH / Synchronous Ethernet equipment, DWDM and Wireless base station.

The device consists of a highly quality and configurable DPLL to provide system clock for node timing synchronization within a SONET / SDH / Synchronous Ethernet network.

An input clock is automatically or manually selected for the DPLL. The DPLL has three primary operating modes: Free-Run, Locked and Holdover. In Free-Run mode, the DPLL refers to the master clock. In Locked mode, the DPLL locks to the selected input clock. In Holdover mode, the DPLL resorts to the frequency data acquired in Locked mode. Whatever the operating mode is, the DPLL gives a stable performance without being affected by operating conditions or silicon process variations.

There is also a high performance APLL that is used for low jitter SONET and Ethernet Clocks

The device provides programmable DPLL bandwidths: 0.5 mHz to 560 Hz. Different settings cover all SONET / SDH clock synchronization requirements.

A highly stable input is required for the master clock in different applications. The master clock is used as a reference clock for all the internal circuits in the device. It can be calibrated within  $\pm 741$  ppm.

All the read/write registers are accessed through a microprocessor interface. The device supports I2C and serial microprocessor interface modes.

In general, the device can be used in Master/Slave application. In this application, two devices should be used together to enable system protection against single chip failure.

# FUNCTIONAL BLOCK DIAGRAM

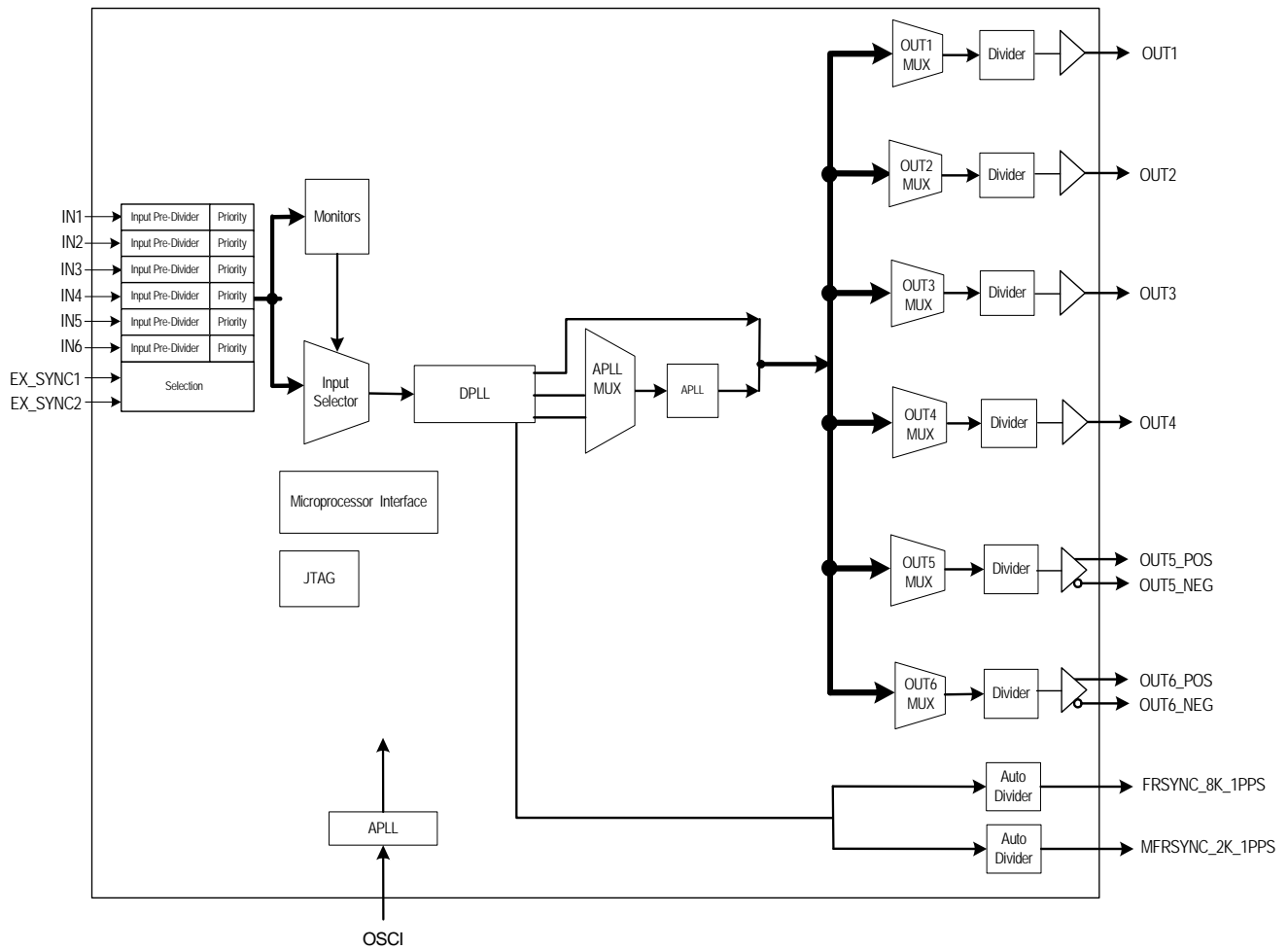

**Figure 1. Functional Block Diagram**

# 1 PIN ASSIGNMENT

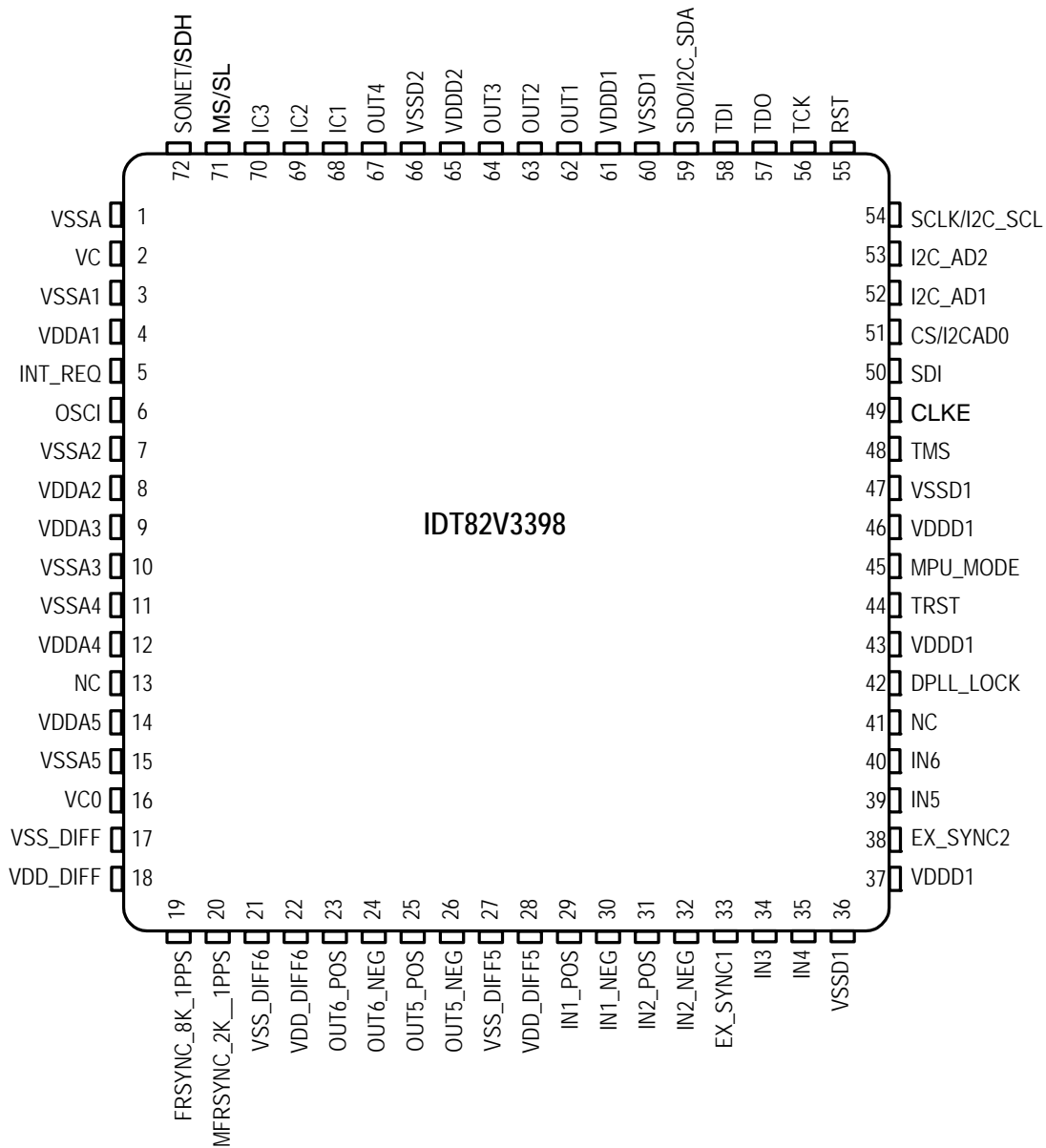

**Figure 2. Pin Assignment (Top View)**

## 2 PIN DESCRIPTION

Table 1: Pin Description

Name	Pin No.	I/O	Type	Description <sup>1,2</sup>
<b>Global Control Signal</b>				
OSCI	6	I	CMOS	<b>OSCI: Crystal Oscillator Master Clock</b> A nominal 12.8000 MHz clock provided by a crystal oscillator is input on this pin. It is the master clock for the device.
MS/SL	71	I pull-up	CMOS	<b>MS/SL: Master / Slave Selection</b> This pin, together with the MS_SL_CTRL bit (b0, 13H), controls whether the device is configured as the Master or as the Slave. Refer to <a href="#">Chapter 3.14 Master / Slave Configuration</a> for details. The signal level on this pin is reflected by the MASTER_SLAVE bit (b1, 09H).
SONET/SDH	72	I pull-down	CMOS	<b>SONET/SDH: SONET / SDH Frequency Selection</b> During reset, this pin determines the default value of the IN_SONET_SDH bit (b2, 09H): High: The default value of the IN_SONET_SDH bit is '1' (SONET); Low: The default value of the IN_SONET_SDH bit is '0' (SDH). After reset, the value on this pin takes no effect.
RST	55	I pull-up	CMOS	<b>RST: Reset</b> A low pulse of at least 50 $\mu$ s on this pin resets the device. After this pin is high, the device will still be held in reset state for 500 ms (typical).
<b>Frame Synchronization Input Signal</b>				
EX_SYNC1	33	I pull-down	CMOS	<b>EX_SYNC1: External Sync Input 1</b> A 2 kHz, 4 kHz, 8 kHz, or 1PPS signal is input on this pin.
EX_SYNC2	38	I pull-down	CMOS	<b>EX_SYNC2: External Sync Input 1</b> A 2 kHz, 4 kHz, 8 kHz, or 1PPS signal is input on this pin.
<b>Input Clock</b>				
IN1_POS IN1_NEG	29 30	I	PECL/LVDS	<b>IN1_POS / IN1_NEG: Positive / Negative Input Clock 1</b> A 1PPS, 2 kHz, 4 kHz, N x 8 kHz <sup>3</sup> , 1.544 MHz (SONET) / 2.048 MHz (SDH), 6.25 MHz, 6.48 MHz, 10 MHz, 19.44 MHz, 25 MHz, 25.92 MHz, 38.88 MHz, 51.84 MHz, 77.76 MHz, 155.52 MHz, 156.25 MHz, 311.04 MHz, 312.5 MHz, 622.08 MHz or 625 MHz clock is differentially input on this pair of pins. Whether the clock signal is PECL or LVDS is automatically detected. Single-ended input for differential input is also supported. Refer to <a href="#">Chapter 9.3.2.3 Single-Ended Input for Differential Input</a> .
IN2_POS IN2_NEG	31 32	I	PECL/LVDS	<b>IN2_POS / IN2_NEG: Positive / Negative Input Clock 2</b> A 1PPS, 2 kHz, 4 kHz, N x 8 kHz <sup>3</sup> , 1.544 MHz (SONET) / 2.048 MHz (SDH), 6.25 MHz, 6.48 MHz, 10 MHz, 19.44 MHz, 25MHz, 25.92 MHz, 38.88 MHz, 51.84 MHz, 77.76 MHz, 155.52 MHz, 156.25 MHz, 311.04 MHz or 312.5 MHz, 622.08 MHz or 625 MHz clock is differentially input on this pair of pins. Whether the clock signal is PECL or LVDS is automatically detected. Single-ended input for differential input is also supported. Refer to <a href="#">Chapter 9.3.2.3 Single-Ended Input for Differential Input</a> .
IN3	34	I pull-down	CMOS	<b>IN3: Input Clock 3</b> A 1PPS, 2 kHz, 4 kHz, N x 8 kHz <sup>3</sup> , 1.544 MHz (SONET) / 2.048 MHz (SDH), 6.25 MHz, 6.48 MHz, 10 MHz, 19.44 MHz, 25 MHz, 25.92 MHz, 38.88 MHz, 51.84 MHz, 77.76 MHz, 155.52 MHz or 156.25 MHz clock is input on this pin.
IN4	35	I pull-down	CMOS	<b>IN4: Input Clock 4</b> A 1PPS, 2 kHz, 4 kHz, N x 8 kHz <sup>3</sup> , 1.544 MHz (SONET) / 2.048 MHz (SDH), 6.25 MHz, 6.48 MHz, 10 MHz, 19.44 MHz, 25 MHz, 25.92 MHz, 38.88 MHz, 51.84 MHz, 77.76 MHz, 155.52 MHz or 156.25 MHz clock is input on this pin.

Table 1: Pin Description (Continued)

Name	Pin No.	I/O	Type	Description <sup>1,2</sup>
IN5	39	I pull-down	CMOS	<b>IN5: Input Clock 5</b> A 1PPS, 2 kHz, 4 kHz, N x 8 kHz <sup>3</sup> , 1.544 MHz (SONET) / 2.048 MHz (SDH), 6.25 MHz, 6.48 MHz, 10 MHz, 19.44 MHz, 25 MHz, 25.92 MHz, 38.88 MHz, 51.84 MHz, 77.76 MHz, 155.52 MHz or 156.25 MHz clock is input on this pin.
IN6	40	I pull-down	CMOS	<b>IN6: Input Clock 6</b> A 1PPS, 2 kHz, 4 kHz, N x 8 kHz <sup>3</sup> , 1.544 MHz (SONET) / 2.048 MHz (SDH), 6.25 MHz, 6.48 MHz, 10 MHz, 19.44 MHz, 25 MHz, 25.92 MHz, 38.88 MHz, 51.84 MHz, 77.76 MHz, 155.52 MHz or 156.25 MHz clock is input on this pin.
<b>Output Frame Synchronization Signal</b>				
FRSYNC_8K_1PPS	19	O	CMOS	<b>FRSYNC_8K_1PPS: 8 kHz Frame Sync Output</b> An 8 kHz signal or a 1PPS sync signal is output on this pin.
MFRSYNC_2K_1PPS	20	O	CMOS	<b>MFRSYNC_2K_1PPS: 2 kHz Multiframe Sync Output</b> A 2 kHz signal or a 1PPS sync signal is output on this pin.
<b>Output Clock</b>				
OUT1	62	O	CMOS	<b>OUT1 ~ OUT4: Output Clock 1 ~ 4</b> A 1PPS, 400 Hz, 2 kHz, 8 kHz, 64 kHz, N x E1 <sup>4</sup> , N x T1 <sup>5</sup> , N x 13.0 MHz <sup>6</sup> , N x 3.84 MHz <sup>7</sup> , 5 MHz, 10 MHz, 20 MHz, E3, T3, 6.48 MHz, 19.44 MHz, 25.92 MHz, 38.88 MHz, 51.84 MHz, 77.76 MHz, 25MHz, 25.78125 MHz, 125 MHz, 128.90625 MHz, 155.52 MHz or 156.25 MHz or 161.1328125 MHz clock is output on these pins.
OUT2	63			
OUT3	64			
OUT4	67			
OUT5_POS	25	O	PECL/LVDS	<b>OUT5_POS / OUT5_NEG: Positive / Negative Output Clock 5</b> A 1PPS, 400 Hz, 2 kHz, 8 kHz, 64 kHz, N x E1 <sup>4</sup> , N x T1 <sup>5</sup> , N x 13.0 MHz <sup>6</sup> , N x 3.84 MHz <sup>7</sup> , 5 MHz, 10 MHz, 20 MHz, 25 MHz, E3, T3, 6.48 MHz, 19.44 MHz, 25.92 MHz, 38.88 MHz, 51.84 MHz, 77.76 MHz, 125 MHz, 128.90625 MHz, 155.52 MHz, 156.25 MHz, 161.1328125 MHz, 311.04 MHz, 312.5 MHz, 322.265625 MHz, 622.08 MHz, 625 MHz or 644.53125 MHz clock is differentially output on these pair of pins.
OUT5_NEG	26			
OUT6_POS	23	O	PECL/LVDS	<b>OUT6_POS / OUT6_NEG: Positive / Negative Output Clock 6</b> A 1PPS, 400 Hz, 2 kHz, 8 kHz, 64 kHz, N x E1 <sup>4</sup> , N x T1 <sup>5</sup> , N x 13.0 MHz <sup>6</sup> , N x 3.84 MHz <sup>7</sup> , 5 MHz, 10 MHz, 20 MHz, 25 MHz, E3, T3, 6.48 MHz, 19.44 MHz, 25.92 MHz, 38.88 MHz, 51.84 MHz, 77.76 MHz, 125 MHz, 128.90625 MHz, 155.52 MHz, 156.25 MHz, 161.1328125 MHz, 311.04 MHz, 312.5 MHz, 322.265625 MHz, 622.08 MHz, 625 MHz or 644.53125MHz clock is differentially output on these pair of pins.
OUT6_NEG	24			
VC	2	O	Analog	<b>VC:</b> This pin must be connected to ground.
VC0	16	O	Analog	<b>VC0: APLL VC Output</b> External RC filter See "APLL" on page 35 for details.
<b>Lock Signal</b>				
DPLL_LOCK	42	O	CMOS	<b>DPLL_LOCK</b> This pin goes high when DPLL is locked
<b>Microprocessor Interface</b>				
CS / I2C_AD0	51	I/O pull-up	CMOS	<b>CS: Chip Selection</b> In Serial mode, this pin is an input. A transition from high to low must occur on this pin for each read or write operation and this pin should remain low until the operation is over. <b>I2C_AD0: Device Address Bit 0</b> In I2C mode, I2C_AD[2:0] pins are the address bus of the microprocessor interface.
INT_REQ	5	O	CMOS	<b>INT_REQ: Interrupt Request</b> This pin is used as an interrupt request. The output characteristics are determined by the HZ_EN bit (b1, 0CH) and the INT_POL bit (b0, 0CH).

Table 1: Pin Description (Continued)

Name	Pin No.	I/O	Type	Description <sup>1, 2</sup>
MPU_MODE	45	I pull-down	CMOS	<b>MPU_MODE: Microprocessor Interface Mode Selection</b> The device supports 2 microprocessor interface modes: I2C and Serial. During reset, these pins determine the default value of the MPU_SEL_CNFG[0] bit(b0, 7FH) as follows: 0: I2C mode 1: Serial mode After reset, these pins are general purpose inputs. The microprocessor interface mode is selected by the MPU_SEL_CNFG[0] bits (b0, 7FH). After reset de-assertion, wait 10 $\mu$ s for the mode to be active. The value of this pin is always reflected by the MPU_PIN_STS[0] bits (b0, 02H).
CLKE	49	I/O pull-down	CMOS	<b>CLKE: SCLK Active Edge Selection</b> In Serial mode, this pin is an input, it selects the active edge of SCLK to update the SDO: High - The falling edge; Low - The rising edge.  See <a href="#">Table 28</a> for details.
SDI	50	I/O pull-down	CMOS	<b>SDI: Serial Data Input</b> In Serial mode, this pin is used as the serial data input. Address and data on this pin are serially clocked into the device on the rising edge of SCLK.  See <a href="#">Table 28</a> for details.
SDO / I2C_SDA	59	I/O pull-down	CMOS	<b>SDO: Serial Data Output</b> In Serial mode, this pin is used as the serial data output. Data on this pin is serially clocked out of the device on the active edge of SCLK.  <b>I2C_SDA: Serial Data Input/Output</b> In I2C mode, this pin is used as the input/output for the serial data.
I2C_AD1	52	I pull-up	CMOS	<b>I2C_AD1: Device Address Bit 1</b> In I2C mode, I2C_AD[2:0] pins are the address bus of the microprocessor interface. In Serial mode, this pin should be connected to ground.
I2C_AD2	53	I pull-up	CMOS	<b>I2C_AD2: Device Address Bit 2</b> In I2C mode, I2C_AD[2:0] pins are the address bus of the microprocessor interface. In Serial mode, this pin should be connected to ground.
SCLK / I2C_SCL	54	I pull-down	CMOS	<b>SCLK: Shift Clock</b> In Serial mode, a shift clock is input on this pin. Data on SDI is sampled by the device on the rising edge of SCLK. Data on SDO is updated on the active edge of SCLK. The active edge is determined by the CLKE.  <b>I2C_SCL: Serial Clock Line</b> In I2C mode, the serial clock is input on this pin.
<b>JTAG (per IEEE 1149.1)</b>				
TRST	44	I pull-down	CMOS	<b>TRST: JTAG Test Reset (Active Low)</b> A low signal on this pin resets the JTAG test port. This pin should be connected to ground when JTAG is not used.
TMS	48	I pull-up	CMOS	<b>TMS: JTAG Test Mode Select</b> The signal on this pin controls the JTAG test performance and is sampled on the rising edge of TCK.
TCK	56	I pull-down	CMOS	<b>TCK: JTAG Test Clock</b> The clock for the JTAG test is input on this pin. TDI and TMS are sampled on the rising edge of TCK and TDO is updated on the falling edge of TCK. If TCK is idle at a low level, all stored-state devices contained in the test logic will indefinitely retain their state.

Table 1: Pin Description (Continued)

Name	Pin No.	I/O	Type	Description <sup>1, 2</sup>
TDI	58	I pull-up	CMOS	<b>TDI: JTAG Test Data Input</b> The test data are input on this pin. They are clocked into the device on the rising edge of TCK.
TDO	57	O	CMOS	<b>TDO: JTAG Test Data Output</b> The test data are output on this pin. They are clocked out of the device on the falling edge of TCK. TDO pin outputs a high impedance signal except during the process of data scanning. This pin can indicate the interrupt of DPLL selected input clock fail, as determined by the LOS_FLAG_ON_TDO bit (b6, 0BH). Refer to <a href="#">Chapter 3.8.1 Input Clock Validity</a> for details.
<b>Power &amp; Ground</b>				
VDDD1	37,43, 46, 61	Power	-	<b>VDDD1: Digital Core Power.</b>
VDDD2	65	Power	-	<b>VDDD2: CMOS CLK Output Power</b>
VDD_DIFF	18	Power	-	<b>VDD_DIFF: Differential I/O Power Supply</b>
VDD_DIFF6	22	Power	-	<b>VDD_DIFF6: Differential I/O Power Supply</b>
VDD_DIFF5	28	Power	-	<b>VDD_DIFF5: Differential I/O Power Supply</b>
VSSD1	36, 47, 60	Ground	-	<b>VSSD1: Digital Core Ground</b>
VSSD2	66	Ground	-	<b>VSSD2: CMOS CLK Output Ground</b>
VSS_DIFF	17	Ground	-	<b>VSS_DIFF: Differential I/O Ground</b>
VSS_DIFF6	21	Ground	-	<b>VSS_DIFF6: Differential I/O Ground</b>
VSS_DIFF5	27	Ground	-	<b>VSS_DIFF5: Differential I/O Ground</b>
VSSA	1	Ground	-	<b>VSSA: Common Ground</b>
VSSA1	3	Ground	-	<b>VSSAn: APLL Ground</b>
VSSA2	7			
VSSA3	10			
VSSA4	11			
VSSA5	15			
VDDA1	4	Power	-	<b>VDDAn: APLL Power</b>
VDDA2	8			
VDDA3	9			
VDDA4	12			
VDDA5	14			
<b>Others</b>				
IC1	68	-	-	<b>IC: Internal Connected</b> Internal Use. These pins should be left open for normal operation.
IC2	69			
IC3	70			
NC	13, 41	-	-	<b>NC: Not connected</b>
<b>Note:</b>				
1. All the unused input pins should be connected to ground; the output of all the unused output pins are don't-care.				
2. The contents in the brackets indicate the position of the register bit/bits.				
3. N x 8 kHz: $1 \leq N \leq 19440$ .				
4. N x E1: N = 1, 2, 3, 4, 6, 8, 12, 16				
5. N x T1: N = 1, 2, 3, 4, 6, 8, 12, 16, 24				
6. N x 13.0 MHz: N = 1, 2				
7. N x 3.84 MHz: N = 1, 2, 4, 8				



## ORDERING INFORMATION

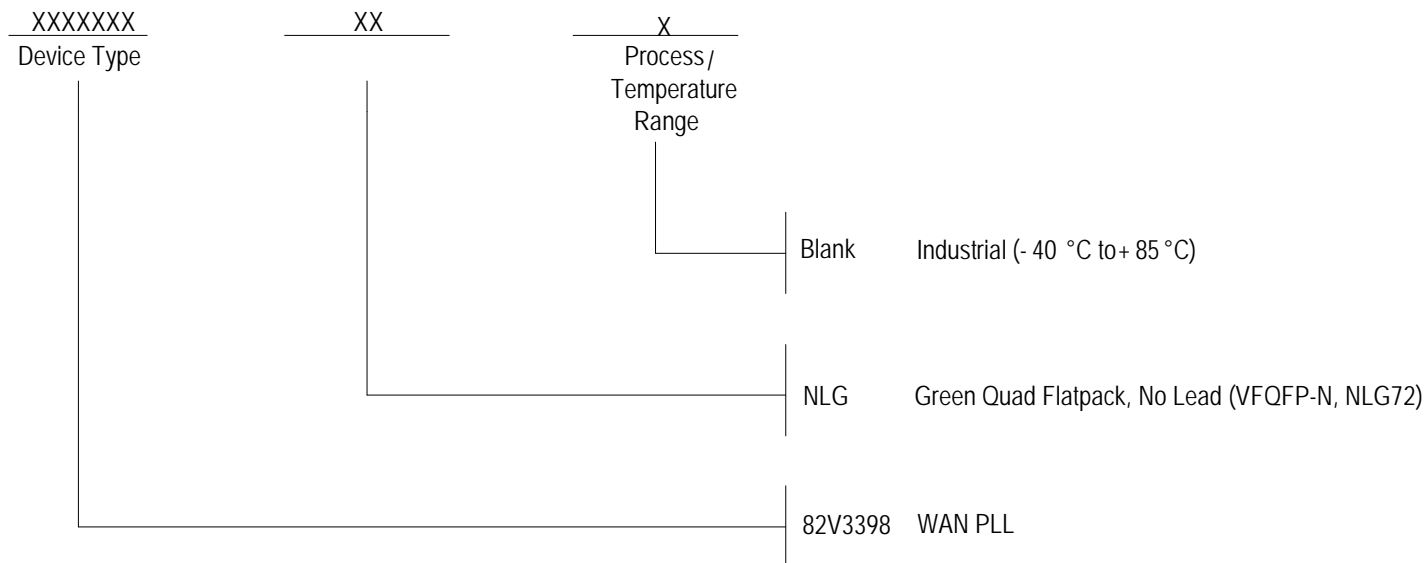

## REVISION HISTORY

August 01, 2012 Initial Release



## IMPORTANT NOTICE AND DISCLAIMER

RENESAS ELECTRONICS CORPORATION AND ITS SUBSIDIARIES (“RENESAS”) PROVIDES TECHNICAL SPECIFICATIONS AND RELIABILITY DATA (INCLUDING DATASHEETS), DESIGN RESOURCES (INCLUDING REFERENCE DESIGNS), APPLICATION OR OTHER DESIGN ADVICE, WEB TOOLS, SAFETY INFORMATION, AND OTHER RESOURCES “AS IS” AND WITH ALL FAULTS, AND DISCLAIMS ALL WARRANTIES, EXPRESS OR IMPLIED, INCLUDING, WITHOUT LIMITATION, ANY IMPLIED WARRANTIES OF MERCHANTABILITY, FITNESS FOR A PARTICULAR PURPOSE, OR NON-INFRINGEMENT OF THIRD-PARTY INTELLECTUAL PROPERTY RIGHTS.

These resources are intended for developers who are designing with Renesas products. You are solely responsible for (1) selecting the appropriate products for your application, (2) designing, validating, and testing your application, and (3) ensuring your application meets applicable standards, and any other safety, security, or other requirements. These resources are subject to change without notice. Renesas grants you permission to use these resources only to develop an application that uses Renesas products. Other reproduction or use of these resources is strictly prohibited. No license is granted to any other Renesas intellectual property or to any third-party intellectual property. Renesas disclaims responsibility for, and you will fully indemnify Renesas and its representatives against, any claims, damages, costs, losses, or liabilities arising from your use of these resources. Renesas' products are provided only subject to Renesas' Terms and Conditions of Sale or other applicable terms agreed to in writing. No use of any Renesas resources expands or otherwise alters any applicable warranties or warranty disclaimers for these products.

(Disclaimer Rev.1.01 Jan 2024)

### Corporate Headquarters

TOYOSU FORESIA, 3-2-24 Toyosu,  
Koto-ku, Tokyo 135-0061, Japan  
[www.renesas.com](http://www.renesas.com)

### Trademarks

Renesas and the Renesas logo are trademarks of Renesas Electronics Corporation. All trademarks and registered trademarks are the property of their respective owners.

### Contact Information

For further information on a product, technology, the most up-to-date version of a document, or your nearest sales office, please visit [www.renesas.com/contact-us/](http://www.renesas.com/contact-us/).