

## Description

The F6522 is an 8-channel transmit active beamforming RFIC designed for application in Ka-Band SATCOM planar phased array antennas. The IC has a single common RF input port and eight output channels. The eight independently controlled output channels can drive eight single-polarized elements or four dual-polarized elements of an electronically scanned array (ESA). Each channel has 6 bits of digital phase control covering 360° and 25dB of gain control with a minimum step size of 0.2dB, enabling precise beam pattern and polarization control.

Operating from a single supply of 2.1 - 2.5V, the RFIC has 28dB of nominal small signal gain with a typical P1dB of 11dBm per channel. The F6522 is highly efficient and features a low power standby mode as well as independent enable controls on every channel. The device's SPI bus and control pins operate from standard 1.8V logic at speeds up to 50MHz. Advanced digital modes and large on-chip memory allows for < 100ns beam position switching times at the array level, greatly reducing dead time and latency.

Finally, the compact and CTE-matched FC-BGA organic package with all single-ended 50ohm matched RF ports greatly simplifies the physical integration of the F6522 onto large antenna panels.

## Typical Applications

- Phased array antennas
- Ka-band SATCOM terminals
- Aerospace and maritime

## Features

- 27.5 – 31.0GHz operation
- Supports 4 dual-pol elements or 8 single-pol
- 360° phase control with 6-bit resolution
- 25dB gain control with 0.2dB minimum step
- 28dB small signal gain
- 11dBm output P1dB
- 2.3V nominal single supply input
- Standard 1.8V digital logic
- Temperature compensation
- Temperature sensor with digital readout
- Advanced digital modes with fast beam steering
- On-chip beam-state memory
- 3.8 × 4.6 × 0.9 mm, 62-pin FC-BGA package

## Block Diagram

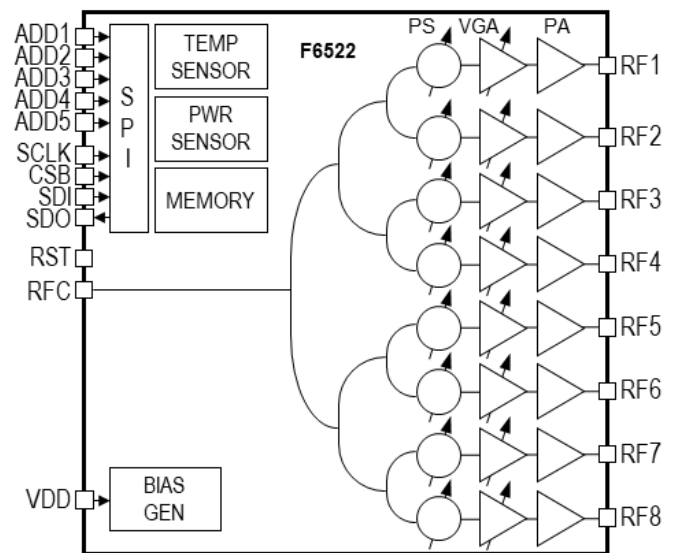

## Ordering Information

Orderable Part Number	Package	MSL Rating	Carrier Type	Temperature
F6522AVGI	3.8 × 4.6 × 0.9 mm 62-BGA	3	Tray	-40°C to +85°C
F6522AVGI8	3.8 × 4.6 × 0.9 mm 62-BGA	3	Reel	-40°C to +85°C
F6522EVS	F6522 Evaluation System. Includes Digital Interface Board, RF Evaluation Board, USB Cable, Power Supply Cable, Digital Interconnect Cable, Evaluation Software, Device Drivers and RF De-embed Files.			

## IMPORTANT NOTICE AND DISCLAIMER

RENESAS ELECTRONICS CORPORATION AND ITS SUBSIDIARIES (“RENESAS”) PROVIDES TECHNICAL SPECIFICATIONS AND RELIABILITY DATA (INCLUDING DATASHEETS), DESIGN RESOURCES (INCLUDING REFERENCE DESIGNS), APPLICATION OR OTHER DESIGN ADVICE, WEB TOOLS, SAFETY INFORMATION, AND OTHER RESOURCES “AS IS” AND WITH ALL FAULTS, AND DISCLAIMS ALL WARRANTIES, EXPRESS OR IMPLIED, INCLUDING, WITHOUT LIMITATION, ANY IMPLIED WARRANTIES OF MERCHANTABILITY, FITNESS FOR A PARTICULAR PURPOSE, OR NON-INFRINGEMENT OF THIRD-PARTY INTELLECTUAL PROPERTY RIGHTS.

These resources are intended for developers who are designing with Renesas products. You are solely responsible for (1) selecting the appropriate products for your application, (2) designing, validating, and testing your application, and (3) ensuring your application meets applicable standards, and any other safety, security, or other requirements. These resources are subject to change without notice. Renesas grants you permission to use these resources only to develop an application that uses Renesas products. Other reproduction or use of these resources is strictly prohibited. No license is granted to any other Renesas intellectual property or to any third-party intellectual property. Renesas disclaims responsibility for, and you will fully indemnify Renesas and its representatives against, any claims, damages, costs, losses, or liabilities arising from your use of these resources. Renesas' products are provided only subject to Renesas' Terms and Conditions of Sale or other applicable terms agreed to in writing. No use of any Renesas resources expands or otherwise alters any applicable warranties or warranty disclaimers for these products.

(Disclaimer Rev.1.01 Jan 2024)

### Corporate Headquarters

TOYOSU FORESIA, 3-2-24 Toyosu,  
Koto-ku, Tokyo 135-0061, Japan  
[www.renesas.com](http://www.renesas.com)

### Trademarks

Renesas and the Renesas logo are trademarks of Renesas Electronics Corporation. All trademarks and registered trademarks are the property of their respective owners.

### Contact Information

For further information on a product, technology, the most up-to-date version of a document, or your nearest sales office, please visit [www.renesas.com/contact-us/](http://www.renesas.com/contact-us/).