

White Paper

Isolated CAN Bus for Small Satellite Applications

Steve Singer, Staff Marketing Engineer, Intersil Space and High Reliability Products, Renesas Electronics Corp.

February 2019

Abstract

Serial communications are an important aspect of complex signal processing and communications systems. Serial buses have been used for decades in satellite designs. However, in modern small satellite applications, the use of Controller Area Network (CAN) busing is being used more and more to replace older bus systems such as RS-422 and RS-485. CAN buses have a few advantages over the older standards, including lower supply and common mode voltages, allowing for easier interface to modern controllers such as microcontrollers. In many cases, an isolated CAN bus must be used to protect systems from high voltage transients and in the prevention of ground loops. Isolated serial buses convey both power and the data signal across the isolation barrier.

Introduction

Small Satellite Overview

Small satellites are becoming a more dominant area of the space and satellite market place. In 2019, it is expected that more than 1,000 small satellites will be launched. Many satellite companies are starting to design and build what are known as “Mega-Constellations.” These are systems of satellites that are intended to have potentially hundreds of satellites flying in Low Earth Orbit (LEO). The mission length for many of these satellites is < 5 years, compared to 15+ years for more traditional satellite missions. These satellites will be used mainly for telecommunications, but have other uses such as scientific exploration and earth observation.



Small satellites represent some important changes from the traditional satellite market. First, as the name implies, small satellites take up substantially less volume and weigh significantly less than traditional satellites. Small satellites are typically defined as having a mass of < 500kg. Another key component of small satellites is reduced cost. In order to build a constellation of 100 or more satellites, the aggregate cost of each of these must be far lower than traditional satellites. These size and cost constraints make it challenging to build satellite electronics using standard Class V and QML radiation-tolerant products. The challenge is that many of these small satellites have some quality and radiation-tolerance requirements that cannot be met using Commercial-Off-The-Shelf (COTS) components.

How the CAN Bus can be used in Small Satellites

The CAN bus protocol is a widely used serial interface that was developed for automotive communications systems. The CAN bus is optimal for allowing microcontrollers or other processing units, such as FPGAs, to communicate with each other. Since the CAN bus is a serial communications link, the number of lanes between different points can be

minimized. The CAN bus can accommodate up to 1Mbps data rate and uses a 2-wire interface mode. The serial nature of the communications can help to reduce overall system area by saving circuit board space as compared to a parallel interface. In addition, a single CAN bus can support multiple CAN transceivers. The Isolated CAN bus may be used to provide protection against transients induced on the bus, including those caused by Single Event Effects (SEE) from heavy ions in the space environment.

This document will discuss using the Radiation-Tolerant Plastic ISL71710M Active Digital Isolator and the ISL71026M Can Transceiver from Renesas in an isolated CAN bus application. Used together, these products can help reduce circuit board area to create fully isolated CAN bus nodes. These space-savings are critical for small satellite applications where circuit board area and size, in general, are at a premium.

Introduction to the CAN Bus

CAN Bus Interface

The CAN bus is a 2-wire serial communications standard that can operate with data rates up to 1Mbps. It uses a physical layer and a data link layer. The physical layer is a differential pair that provides common mode noise rejection. The data layer defines the signals that are transmitted along the physical layer.

Each CAN controller on the network has a unique ID to avoid bus contention. In order for this to work, all CAN controllers on the network must sample every bit at the same time. Even though there is no master clock, the CAN bus network can be thought of as synchronous.

For the physical layer implementation, the CAN bus requires a $R_L = 120\Omega$ resistor placed differentially between the CANH and CANL bus lines. The bus requires that the R_L be placed at both ends of the bus, meaning that the first and last nodes in the CAN bus must have the R_L placed in order to obtain the correct signal levels. The recessive state voltage for the CAN bus is approximately 2.3V. In the dominant state, CANH goes up to approximately 3V and CANL goes down to approximately 1V.

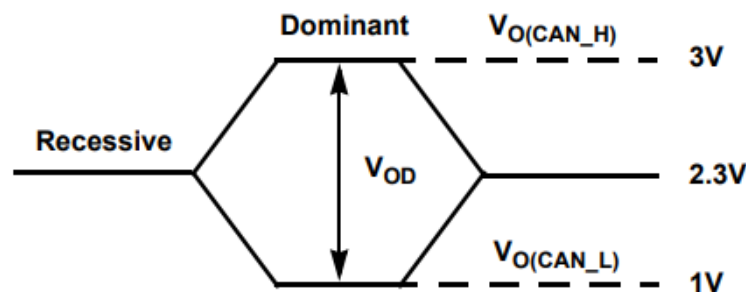

Figure 1: ISL71026M Dominant and Recessive Output States

Node Definition and Layers

Each node on the network requires three elements. The first is a processing unit such as a microcontroller, FPGA, or microprocessor. Second, a CAN controller must be present. The CAN controller formats the data into the appropriate format for the CAN bus. Lastly, the node needs a transceiver. This is the physical interface that ensures that the CAN bus voltage levels are met and translate between the controller voltage levels and the bus voltage levels.

The CAN protocol has three abstraction layers in the signaling. The application layer handles the message and statuses, as well as message filtering. The transfer layer is responsible for bit timing and synchronization, message framing, arbitration, and error detection. The physical layer defines the electrical properties of the CAN bus. The signal layers on the CAN bus are typically referred to as CAN+ and CAN- to form the differential pair.

CAN Bus Network

Using the CAN bus interface, multiple nodes can be connected to a single bus. The CAN bus protocol supports a maximum of 30 nodes. This is advantageous as all 30 nodes can share the same bus. The destination address is transmitted over the bus itself, thus eliminating the need for a select line such as required when using a SPI bus.

The CAN bus network can be used effectively in a distributed computing application. For example, a satellite payload may have multiple environmental or positioning sensors spread out across the payload board. Using an isolated CAN bus to communicate between different CAN bus nodes is an efficient way to transmit sensor and position data. The isolation ensures protection for the CAN controller. In many cases, the CAN controller can be an expensive or critical component, so it is essential to provide adequate protection to the CAN controller.

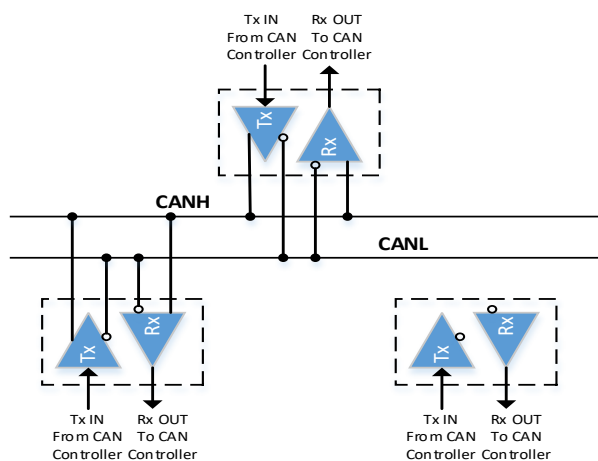

Figure 2: CAN bus network with multiple nodes

Radiation-Tolerant Plastic Isolated CAN Solution

Introduction to Radiation-Tolerant Plastic Products from Renesas

Renesas currently has a portfolio of products that are specifically designed for small satellite applications. These products have a higher level of qualification than COTS components that is similar to automotive grade semiconductor products. In addition, the products in this portfolio have been screened for radiation tolerance. For all of these products, the radiation data is published in the datasheet.

The ISL71026M is a currently released CAN Transceiver that follows the radiation-tolerant plastic flow outlined above. The ISL71026M is a radiation-tolerant 3.3V CAN Transceiver that can operate up to the maximum CAN bus data rate of 1Mbps. Figure 3 below shows an application diagram of the ISL71026M.

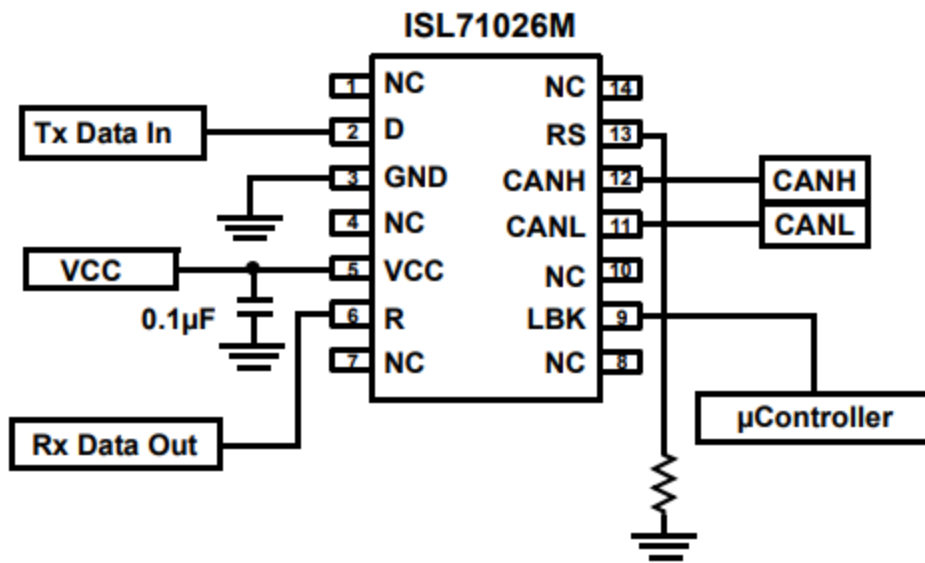

Figure 3: Application Diagram of the ISL71026M

The ISL71710M is a currently released Active Input Digital Isolator that follows the radiation-tolerant plastic flow. The ISL71710M uses an isolation technology that works on the principles of Giant Magneto Resistive (GMR) effects. This technology allows efficient digital isolation with low quiescent current, no EMI concerns, and no issues with optics greying over time.

The GMR Technology works using a coil on the input side. This coil is energized and driven by the input buffer, and the polarity depends on the output state of the buffer. This energized coil produces an electric field across the isolation barrier and induces a change in resistance of the GMR elements. As the resistance changes, it causes the output to change the state accordingly. Figure 4 below shows the GMR technology.

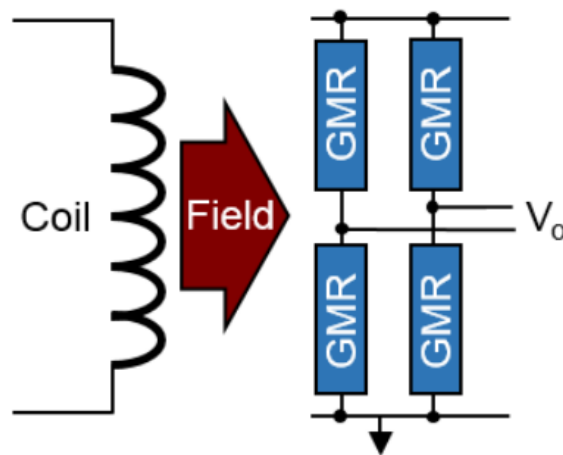

Figure 4: ISL71710M GMR technology diagram

Using the ISL71710M with the ISL71026M to create an isolated CAN Bus

The ISL71710M is an ideal choice to use with a CAN transceiver, such as the ISL71026M, to create a fully isolated CAN bus. It is important to note that the ISL71710M digital isolator must be placed in between the CAN controller; i.e., MCU and the CAN transceiver. This will allow the sensitive microcontroller supply to be fully isolated from the CAN

bus supply. It is important to note that while the ISL71710M will inherently provide isolation for the data signals, the power supplies for the ISL71710M and the CAN controller must also be isolated. If these are simply tied together, the benefits of using a digital isolator cannot be realized. See Figure 5 for an application diagram of the isolated CAN bus circuit.

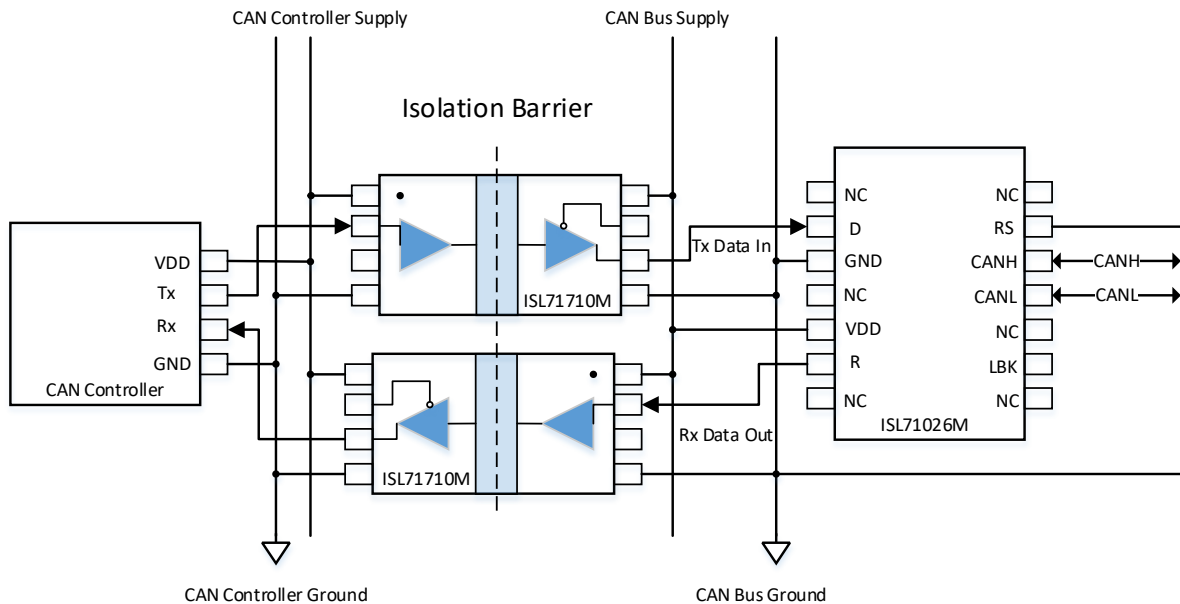

Figure 5: Isolated CAN Bus Using ISL71710M and ISL71026M

Space Savings

As previously stated, area is at a premium on circuits boards for small satellite applications. As such, semiconductor manufacturers need to be sensitive to the needs of small satellite producers. Using the Renesas Radiation-Tolerant Plastic Flow gives customers the option to reduce the size of their isolated CAN bus solution significantly. See Table 1 for a comparison to isolated CAN bus solutions in hermetic packages.

Manufacturer	CAN Transceiver Size	Digital Isolator Size
Renesas RT Plastic	20mm ²	20mm ²
Renesas QML ₁	45mm ²	20mm ²
Supplier A	49mm ²	Not Offered
Supplier B	Not Offered	77mm ²
Supplier C	19.5mm ²	Not Offered
Supplier D	255mm ²	Not Offered

Table 1. Different Isolated CAN bus solution size.

Note: The data listed in the table was obtained from the datasheets of the vendors listed in the manufacturer column.

Footnote 1: Renesas only offers the digital isolator in a plastic package.

Cost Savings

Since the ISL71710M and the ISL71026M are packaged using plastic packages, much of the cost of typical space products has been removed. In addition, standard Class V flow for space semiconductors has many production level tests that add significantly to the cost. These tests include visual inspection, radiography, 100% burn in, and 100% temperature cycling. Removing these in-line production tests allows Renesas to pass the cost savings of those products on to customers.

For more information about the radiation-tolerant plastic portfolio from Renesas, please see the link at the end of this paper.

Summary

Using an isolated CAN bus for a small satellite application not only allows the designer to protect the sensitive electronics in the CAN controller, but by using the radiation-tolerant plastic products from Renesas, it is achievable in a way that meets the simultaneous requirements of smaller, active IC footprints and reduced costs.

Design Tools from Renesas

Evaluation Board/User Guide

Evaluation boards and detailed user guides for customer testing and evaluation are available for the ISL71710M and ISL71026M. Photographs of the evaluation boards are shown in Figures 6 and 7.

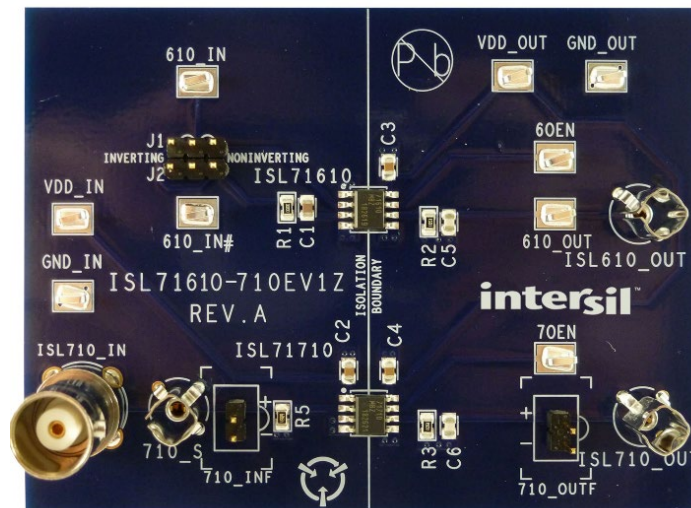

Figure 6: The ISL71710M Evaluation Board

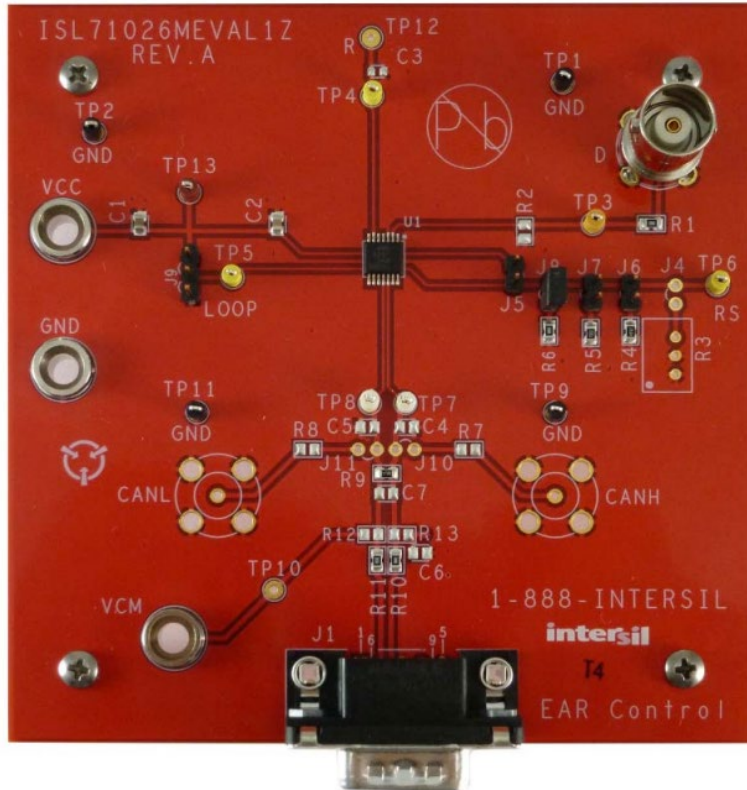

Figure 7: The ISL71026M Evaluation Board

Additional Resources

For other online resources provided by Renesas for radiation-tolerant plastic space products, as well as the link to the ISL71710M and ISL71026M, go to:

ISL71710M Overview: <https://www.renesas.com/us/en/products/space-harsh-environment/rad-tolerant-digital/rt-isolators/device/ISL71710M.html>

ISL71710M Data Sheet: <https://www.renesas.com/us/en/www/doc/datasheet/isl71710m.pdf>

ISL71710M Evaluation Board User's Guide: <https://www.renesas.com/us/en/www/doc/guide/isl71610-710ev1z-user-guide.pdf>

ISL71026M Overview: <https://www.renesas.com/us/en/products/space-harsh-environment/rad-tolerant-analog/rt-can-bus-transceivers/device/ISL71026M.html>

ISL71026M User's Guide: <https://www.renesas.com/en-us/www/doc/guide/isl71026meval1z-user-guide.pdf>

White Paper: <https://www.renesas.com/us/en/doc/whitepapers/rad-hard/powering-small-satellite-constellations-with-plastic-ics.pdf>

© 2019 Renesas Electronics America Inc. (REA). All rights reserved. All trademarks and trade names are those of their respective owners. REA believes the information herein was accurate when given but assumes no risk as to its quality or use. All information is provided as-is without warranties of any kind, whether express, implied, statutory, or arising from course of dealing, usage, or trade practice, including without limitation as to merchantability, fitness for a particular purpose, or non-infringement. REA shall not be liable for any direct, indirect, special, consequential, incidental, or other damages whatsoever, arising from use of or reliance on the information herein, even if advised of the possibility of such damages. REA reserves the right, without notice, to discontinue products or make changes to the design or specifications of its products or other information herein. All contents are protected by U.S. and international copyright laws. Except as specifically permitted herein, no portion of this material may be reproduced in any form, or by any means, without prior written permission from Renesas Electronics America Inc. Visitors or users are not permitted to modify, distribute, publish, transmit or create derivative works of any of this material for any public or commercial purposes.